

4MSX

MOTORI SOMMERSI 4"
 4" SUBMERSIBLE MOTORS
 MOTEURS IMMERGÉES 4"
 MOTORES SUMERGIDOS 4"

50 Hz - $n \approx 2900$ rpm

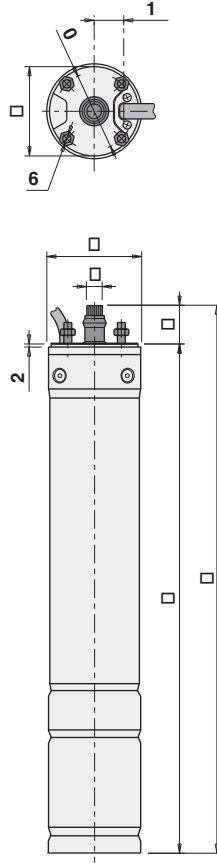

Disegno per lo smontaggio ed il rimontaggio
Drawing for dismantling and assembly
Dessin pour démontage et montage
Dibujo para desmontaje y montaje

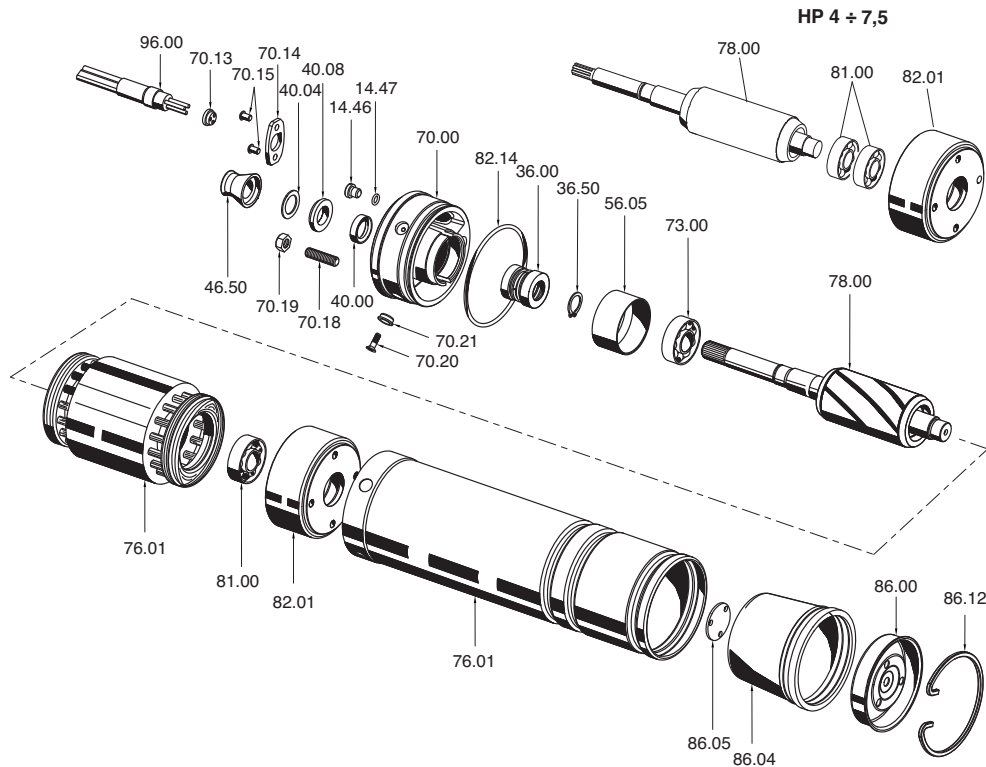

Italiano	English	Français	Español
POS. DENOMINAZIONE	POS. DENOMINATION	POS. DENOMINATION	POS. DENOMINACION
14.46 Tappo Olio	14.46 Oil Cap	14.46 Bouchon Huile	14.46 Tapón Aceite
14.47 O-ring	14.47 O-ring	14.47 Bague OR	14.47 O-ring
36.00 Tenuta Meccanica	36.00 Mechanical Seal	36.00 Tenue Mechanique	36.00 Sello mecánico
36.50 Anello di sicurezza tenuta mec.	36.50 Mechanical seal circlip	36.50 Circlips	36.50 Anillo seguridad sello mec.
40.00 Anello di tenuta radiale	40.00 Radial shaft seal	40.00 Joint à lèvres	40.00 Anillo de cierre radial
40.04 Coperchio membrana statore	40.04 Spacer	40.04 Entretoise	40.04 Espaciador
40.08 Anello Rasamento	40.08 Adjusting Ring	40.08 Bague De Reglage	40.08 Anillo De Ajuste
46.50 Parasabbia	46.50 Sand Protection	46.50 Parasable	46.50 Anillo Anti-arena
56.05 Camicia cavi	56.05 Cable jacket	56.05 Chemise cacle	56.05 Camisa cable
70.00 Flangia Motore Supporto Sup.	70.00 Motor Flange	70.00 Bride Moteur	70.00 Brida Motor
70.13 Rondella NYLON	70.13 Washer	70.13 Rondelle	70.13 Arandela
70.14 Piastrina	70.14 Cable fastener	70.14 Plaque de serrage cable	70.14 Placa de apriete cable
70.15 Vite	70.15 Screw	70.15 Vis	70.15 Tornillo
70.18 Prigioniero	70.18 Stud Bolt	70.18 Goujon	70.18 Perno Prisonero
70.19 Dado	70.19 Nut	70.19 Ecrou	70.19 Tuerca
70.20 Vite	70.20 Screw	70.20 Vis	70.20 Tornillo
70.21 Rosetta	70.21 Washer	70.21 Rondelle	70.21 Arandela
73.00 Cuscinetto superiore	73.00 Bearing	73.00 Coussinet	73.00 Cojinete
76.01 Camicia motore con avvolgimento	76.01 Motor jacket with winding	76.01 Chemise moteur avec bobinage	76.01 Camisa motor bobinado
78.00 Albero con Rotore	78.00 Shaft with rotor packet	78.00 Arbre-rotor	78.00 Eje con rotor
81.00 Cuscinetto Inferiore	81.00 Ball bearing	81.00 Roulement à billes	81.00 Cojinete
82.01 Supporto Inferiore	82.01 Lower Support	82.01 Support Inf.	82.01 Soporte Inf.
82.14 O-ring	82.14 O-ring	82.14 Bague OR	82.14 O-ring
86.00 Coperchio membrana statore	86.00 Stator membrane cover	86.00 Couvercle de membrane stator	86.00 Cuerpo membrana stator
86.12 Anello di fissaggio	86.12 Fastening Ring	86.12 Anneau de fixation	86.12 Anillo de fijación
86.04 Membrana	86.04 Membrane	86.04 Membrane	86.04 Membrana
86.05 Disco protezione membrana	86.05 Diapham protection plate	86.05 Flasque protection membrane	86.05 Disco protección membrana
96.00 Cavo	96.00 Cable	96.00 Cable	96.00 Cable