

4MS

4" SUBTECK OIL FILLED SUBMERSIBLE MOTORS

60 Hz - n ≈ 3500 rpm



Construction features

4" rewindable submersible motors filled with food grade dielectric fluid (USA FDA, European Pharmacopeia approved).
 Motor housing and lower support, made in s.s. AISI 304, external shaft in s.s. AISI 316, cast-iron nickel-plated upper bracket amply sized rubber equalization diaphragm.
 4" NEMA standards, four conductors flat electric cable suitable for use in drinking water, 0,5-3,0 HP length 2,0 m, 4,0-7,5 HP length 3,0 m.
 Triple seal system on rotor shaft: bi-directional mechanical seal+radial seal+sand-guard
 Single phase motors: PSC type (Permanent Split Capacitor)
 Rotation: Single phase motors, clockwise facing shaft end, three phase, clockwise or counter clockwise without distinction.
 All motors are 100% tested.

Operation data

Power : from 0,5 HP to 3 HP (from 0,37 to 2,2 kW) for singlephase motors
 from 0,5 HP to 7,5 HP (from 0,37 to 5,5 kW) for threephase motors
 Rotation speed : about 3500 r.p.m.
 Alimentation tension : 220V singlephase, 220V - 380V - 460V threephase
 Tension change : max + 6% min -10%
 Frequency : 60 Hz / 2 poles
 Starting : D.O.L.
 N° of starting/h : max 20
 Water temperature : 35 °C - F 100
 Horizontal operation : up to 3 HP (2,2 kW) included
 Insulation : Class F
 Protection : IP 68
 Continuous service : Yes
 Cooling flow : min 0,8 m/sec



Single phase

Code	P ₂		I _n (Amp)		Power factor (cosφ)	Efficiency η%	R.P.M.	Direct Start		Axial Thrust N	Service Factor	I with S.F. (Amp)		Capacitor 450VC μF
	KW	HP	220V	230V				I _A /I _N	C _A /C _N			220V	230V	
4MS 037M	0,37	0,5	3,8	4,0	0,94	49	≈3450	4,1	0,94	1500	1,6	4,9	5,2	16
4MS 055M	0,55	0,75	4,6	4,7	0,98	57		5,4	0,97		1,5	5,8	6,0	25
4MS 075M	0,75	1	6,5	6,7	0,93	58		4,2	0,80		1,4	7,9	8,1	30
4MS 110M	1,1	1,5	9,4	9,6	0,88	62		4,6	0,79		1,3	10,6	1,1	40
4MS 150M	1,5	2	12,0	12,7	0,91	61		4,5	0,92		1,25	13,1	13,5	60
4MS 220M	2,2	3	15,6	16,0	0,95	66		5,2	0,62		1,15	17,4	19,0	70

Code	P ₂		I _n (Amp)			Power factor (cosφ)	Efficiency η%	R.P.M.	Direct Start		Axial Thrust N	Service Factor	I with S.F. (Amp)		
	KW	HP	220V	380V	460V				I _A /I _N	C _A /C _N			220V	380V	460V
4MS 037T	0,37	0,5	2,5	1,5	1,2	0,67	60	≈3450	5,6	5,14	1500	1,6	3,1	1,8	1,5
4MS 055T	0,55	0,75	3,0	1,8	1,5	0,74	67		6,3	5,01		1,5	3,9	2,3	1,9
4MS 075T	0,75	1	4,5	2,1	2,1	0,72	64		4,4	3,62		1,4	5,4	3,1	2,6
4MS 110T	1,1	1,5	5,5	3,2	2,6	0,75	73		5,1	3,66		1,3	6,7	3,9	3,2
4MS 150T	1,5	2	7,4	4,3	3,5	0,74	76		5,2	3,75		1,25	8,5	4,9	4,1
4MS 220T	2,2	3	10,4	6,0	5,0	0,81	72		5,4	2,2		1,15	13,5	7,8	6,4
4MS 300T	3	4	13,7	7,9	6,5	0,75	77		6,6	3,7		1,15	15,1	8,7	7,2
4MS 400T	4	5,5	17,3	10,0	8,3	0,76	79		7,2	2,5		1,15	19,2	11,1	9,2
4MS 550T	5,5	7,5	23,1	13,3	11,0	0,79	80		7,6	4,4		1,15	25,8	14,9	12,3

Code	P ₂		phase	Dimensions (mm)											Weight Kg.
	KW	HP		A	B	C	D	E	F	M	N	O	S		
4MS 037M	0,37	0,5	1	365	327	38 ±0,30 ±0,05	∅95	∅87,3 h8	∅15,5 +0,1 ±0	∅76 ±0,1	33	3		7,6	
4MS 055M	0,55	0,75		400	362									9,4	
4MS 075M	0,75	1		400	362									9,4	
4MS 110M	1,1	1,5		440	402									10,7	
4MS 150M	1,5	2		485	447									12,4	
4MS 220M	2,2	3		555	517									15,7	
4MS 037T	0,37	0,5	3	365	327						7,7				
4MS 055T	0,55	0,75		365	327						7,7				
4MS 075T	0,75	1		385	347						8,7				
4MS 110T	1,1	1,5		400	362						9,5				
4MS 150T	1,5	2		440	402						10,8				
4MS 220T	2,2	3		440	402						11,7				
4MS 300T	3	4		519	481	15,1									
4MS 400T	4	5,5		584	546	18,1									
4MS 550T	5,5	7,5		684	646	22,5									

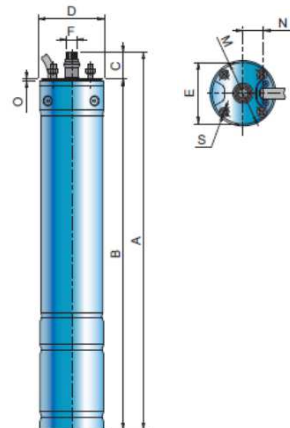

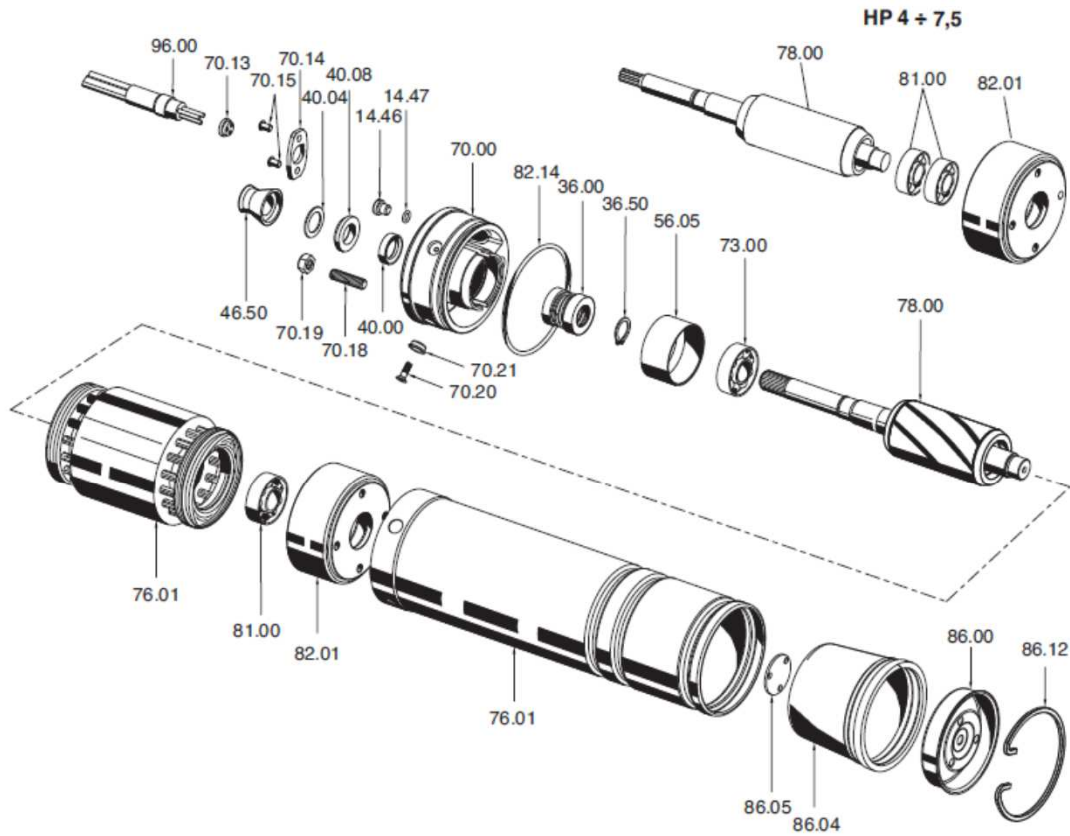

POS.	DENOMINATION	Q.ty.
14.46	Oil Cap	2
14.47	O-ring	2
36.00	Mechanical Seal	1
36.50	Mechanical seal circlip	1
40.00	Radial shaft seal	1
40.04	Spacer	1
40.08	Adjusting Ring	1
46.50	Sand Protection	1
56.05	Cable jacket	1
70.00	Motor Flange	1
70.13	Washer	1
70.14	Cable fastener	1
70.15	Screw	2
70.18	Stud Bolt	4
70.19	Nut	4
70.20	Screw	4
70.21	Washer	4
73.00	Bearing	1
76.01	Motor jacket with winding	1
78.00	Shaft with rotor packet	1
81.00	Ball bearing	1
82.01	Lower Support	1
82.14	O-ring	1
86.00	Stator membrane cover	1
86.12	Fastening Ring	1
86.04	Membrane	1
86.05	Diaphragm protection plate	1
96.00	Cable	1