

50 Hz
 n ≈ 2900 rpm

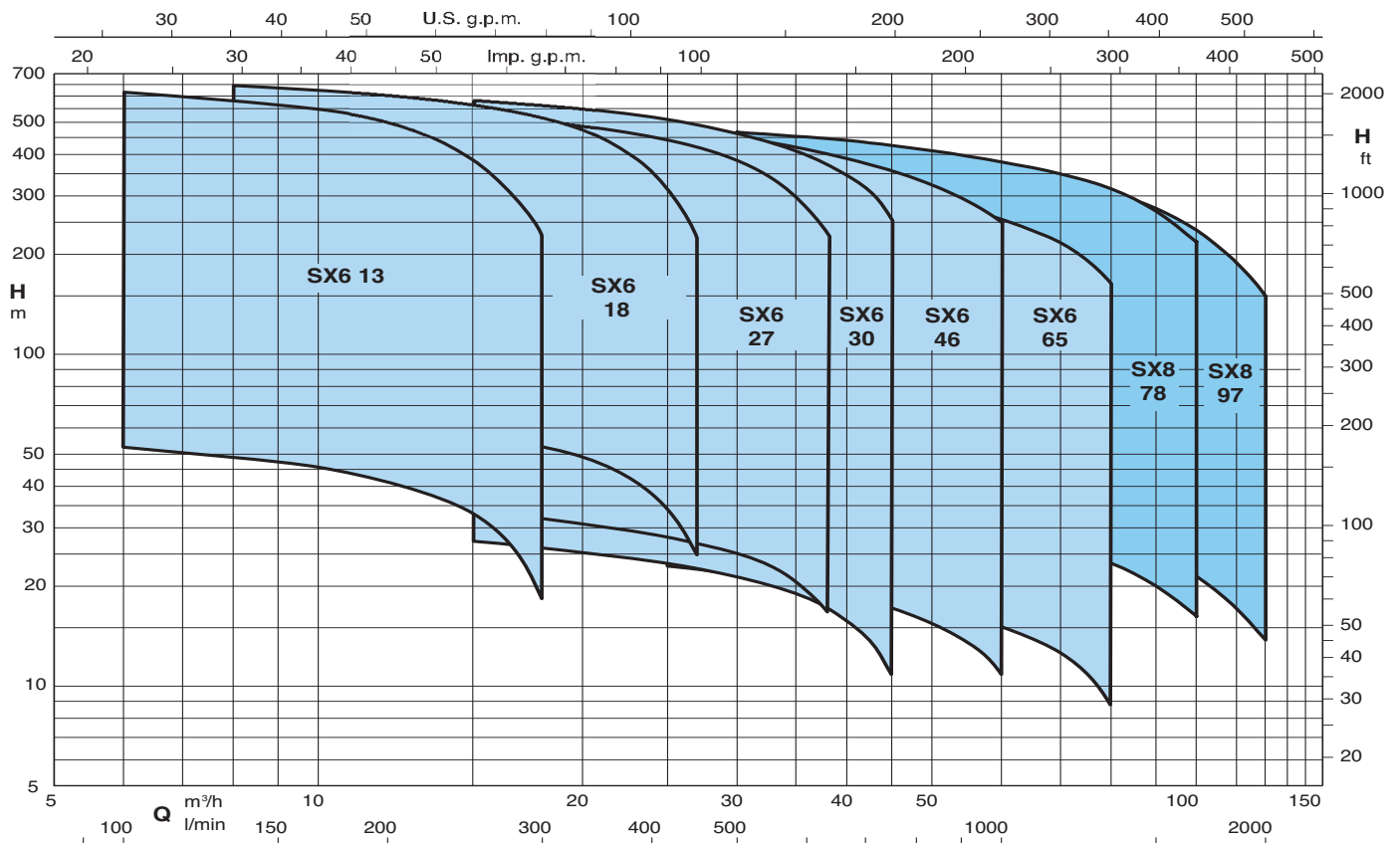

Campo di applicazione - Coverage chart - Graphique d'utilisation - Campo de aplicaciones



Tolleranze secondo ISO 9906-A - Tolerances according to ISO 9906-A - Tolérances suivant ISO 9906-A - Tolerancias según ISO 9906-A
 Le curve di prestazione sono basate su valori di viscosità cinematica = 1 mm²/s e densità pari a 1000 kg/m³ - Les courbes de performances sont basées sur des valeurs de viscosité cinématique égale à 1 mm²/s et une densité égale à 1000 kg/m³
 The performance curves are based on the kinematic viscosity values = 1 mm²/s and density equal to 1000 kg/m³ - Las curvas de rendimiento se refieren a valores de viscosidad cinemática = 1 mm²/s y densidad de 1000 kg/m³



**POMPE SOMMERSE 6", 8"
6", 8" SUBMERSIBLE PUMPS
POMPES IMMERGEES 6", 8"
BOMBAS SUMERGIDAS 6", 8"**



Esecuzione

Elettropompe sommerse di acciaio inossidabile al nichel-cromo per pozzi profondi da 6" (DN 150 mm) e 8" (DN 200 mm).

SX: con camicia esterna e stadi in acciaio inossidabile AISI 304.

SX-N: con camicia esterna e stadi in acciaio inossidabile AISI 316.

Giranti

Radiali: SX6 13-18-27

Semiassiali: SX6 30-46-65, SX8 78-97

Bocca: Filettata ISO 228

Valvola di ritegno incorporata nel corpo di mandata.

Impieghi

Per l'approvvigionamento d'acqua. Per applicazioni civili e industriali. Per impianti antincendio. Per irrigazione.

Limiti d'impiego

Temperatura acqua fino a 25 °C.

Massima quantità di sabbia nell'acqua: 100 g/m³.

Servizio continuo.

Materiali

Componenti	SX6	SX6 N	SX8	SX8 N
Camicia esterna	Acciaio Cr Ni AISI 304	Acciaio Cr Ni Mo AISI 316L	Acciaio Cr Ni AISI 304	Acciaio Cr Ni Mo AISI 316
Lanterna aspirante	Acciaio Cr Ni Mo AISI 316L	-	-	-
Coperchio superiore	Acciaio Cr Ni Mo AISI 316L	-	-	-
Corpo di mandata	Acciaio Cr Ni Mo AISI 316L	Acciaio Cr Ni Mo AISI 316L	Acciaio Cr Ni AISI 304	Acciaio Cr Ni Mo AISI 316
Filtro, Valvola completa	Acciaio Cr Ni Mo AISI 316			
O-ring valvola	NBR			
Albero	Acciaio Cr Ni Mo AISI 316	Acciaio Cr Ni Mo AISI 316	Acciaio Cr Ni Mo AISI 329	Acciaio Cr Ni Mo AISI 329
Giunto completo	Acciaio Cr Ni Mo AISI 316/329			
Diffusore	Acciaio Cr Ni AISI 304	Acciaio Cr Ni Mo AISI 316L	Acciaio Cr Ni AISI 304	Acciaio Cr Ni Mo AISI 316
Corpo stadio	Acciaio Cr Ni AISI 304	Acciaio Cr Ni Mo AISI 316L	Acciaio Cr Ni AISI 304	Acciaio Cr Ni Mo AISI 316
Girante	Acciaio Cr Ni AISI 304	Acciaio Cr Ni Mo AISI 316L	Acciaio Cr Ni Mo AISI 316	Acciaio Cr Ni Mo AISI 316
Anello di tenuta	Teflon (PTFE)			
Cuscinetto di guida	NBR			
Copricavo, Viteria	Acciaio Cr Ni Mo AISI 316			

Esecuzioni speciali a richiesta

- Altre tensioni. - Frequenza 60 Hz.



Exécution

Electropompe immergées en acier inoxydable au chrome-nickel pour puits de 6" (DN 150 mm) et 8" (DN 200 mm).

SX: avec chemise extérieure et étages en acier inox AISI 304

SX N: avec chemise extérieure et étages en acier inox AISI 316.

Roues

Roues radiales: SX6 13-18-27

Roues hélicocentrifuges: SX6 30-46-65, SX8 78-97

Orifice: Orifice fileté ISO 228

Clapet de retenue incorporé dans le corps de refoulement.

Utilisations

Pour eau propres, non agressifs. Pour l'approvisionnement en eau.

Pour irrigation. Pour applications civiles, industrielles et pour services incendie.

Limites d'utilisations

Température de l'eau jusqu'à 25 °C.

Max quantité de sable dans l'eau: 100 g/m³.

Servicio continuo.

Matériaux

Composants	SX6	SX6 N	SX8	SX8 N
Chemise extérieure	Acier Cr-Ni AISI 304	Acier Cr-Ni-Mo AISI 316L	Acier Cr-Ni AISI 304	Acier Cr-Ni-Mo AISI 316
Lanterne d'aspiration	Acier Cr-Ni Mo AISI 316L	-	-	-
Couvercle supérieur	Acier Cr-Ni-Mo AISI 316L	-	-	-
Corps de refoulement	Acier Cr-Ni-Mo AISI 316L	Acier Cr-Ni Mo AISI 316L	Acier Cr-Ni AISI 304	Acier Cr-Ni-Mo AISI 316
Panier, Clapet, ensemble	Acier Cr-Ni-Mo AISI 316			
Joint de clapet	NBR			
Arbre	Acier Cr-Ni-Mo AISI 316	Acier Cr-Ni-Mo AISI 316	Acier Cr-Ni-Mo AISI 329	Acier Cr-Ni-Mo AISI 329
Accouplement, ensemble	Acier Cr-Ni-Mo AISI 316/329			
Diffuseur	Acier Cr-Ni AISI 304	Acier Cr-Ni-Mo AISI 316L	Acier Cr-Ni AISI 304	Acier Cr-Ni-Mo AISI 316
Corps d'étage	Acier Cr-Ni AISI 304	Acier Cr-Ni-Mo AISI 316L	Acier Cr-Ni AISI 304	Acier Cr-Ni-Mo AISI 316
Roue	Acier Cr-Ni AISI 304	Acier Cr-Ni-Mo AISI 316L	Acier Cr-Ni AISI 304	Acier Cr-Ni-Mo AISI 316
Bague d'étanchéité	Teflon (PTFE)			
Coussinet	NBR			
Profilé protégé-câble, Vis	Acier Cr-Ni-Mo AISI 316			

Exécutions spéciales sur demande

- Autres tensions. - Fréquence 60 Hz.



Construction

Submersible motor pumps in chrome-nickel stainless steel for deep wells of 6" (DN 150 mm) and 8" (DN 200 mm).

SX: with external jacket and stages in stainless steel AISI 304.

SX N: with external jacket and stages in stainless steel AISI 316.

Impellers

Radial impellers: SX6 13-18-27

Mixed flow impellers: SX6 30-46-65, SX8 78-97

Connection: Screwed connection ISO 228

Delivery casing with built-in non-return valve.

Applications

For clean water, non-aggressive. For water supply. For irrigation. For civil and industrial applications. For fire fighting applications.

Operating conditions

Liquid temperature up to a 25 °C.

Max. sand quantity into the water: 100 g/m³.

Continuous duty.

Materials

Components	SX6	SX6 N	SX8	SX8 N
External jacket	Cr-Ni steel AISI 304	Cr-Ni-Mo steel AISI 316L	Cr-Ni steel AISI 304	Cr-Ni-Mo steel AISI 316
Suction lantern	Cr-Ni-Mo steel AISI 316L	-	-	-
Upper cover	Cr-Ni-Mo steel AISI 316L	-	-	-
Delivery casing	Cr-Ni-Mo steel AISI 316L	Cr-Ni-Mo steel AISI 316L	Cr-Ni steel AISI 304	Cr-Ni-Mo steel AISI 316
Strainer, Valve set	Cr-Ni-Mo steel AISI 316			
O-ring valve	NBR			
Shaft	Cr-Ni-Mo steel AISI 316	Cr-Ni-Mo steel AISI 316	Cr-Ni-Mo steel AISI 329	Cr-Ni-Mo steel AISI 329
Coupling set	Cr-Ni-Mo steel AISI 316/329			
Diffuser	Cr-Ni steel AISI 304	Cr-Ni-Mo steel AISI 316L	Cr-Ni steel AISI 304	Cr-Ni-Mo steel AISI 316
Stage casing	Cr-Ni steel AISI 304	Cr-Ni-Mo steel AISI 316L	Cr-Ni steel AISI 304	Cr-Ni-Mo steel AISI 316
Impeller	Cr-Ni steel AISI 304	Cr-Ni-Mo steel AISI 316L	Cr-Ni-Mo steel AISI 316	Cr-Ni-Mo steel AISI 316
Wear ring	Teflon (PTFE)			
Bearing bush	NBR			
Cable guard, Screws	Cr-Ni-Mo steel AISI 316			

Special features on request

- Other voltages. - 60 Hz frequency.



Ejecución

Electrobombas sumergibles de acero inoxidable al níquel-cromo para pozos profundos de 6" (DN 150 mm) y 8" (DN 200 mm).

SX: con camisa externa y etapas en acero inoxidable AISI 304.

SX N: con camisa externa y etapas en acero inoxidable AISI 316.

Rodetes

Radiales: SX6 13-18-27

Semi-axiales: SX6 30-46-65, SX8 78-97

Conexión: Boca roscada ISO 228

Válvula de retención incorporada en el cuerpo de impulsión.

Aplicaciones

Para agua limpias, no agresivas. Para suministros de agua. Para riegos en general. Para aplicaciones civiles, industriales e contra incendios.

Limites de empleo

Temperatura del agua hasta 25 °C.

Máxima cantidad de arena en el agua: 100 g/m³.

Servicio continuo.

Materiales

Componentes	SX6	SX6 N	SX8	SX8 N
Camisa externa	Acero Cr-Ni AISI 304	Acero Cr-Ni-Mo AISI 316L	Acero Cr-Ni AISI 304	Acero Cr-Ni-Mo AISI 316
Lanterna de aspiración	Acero Cr-Ni Mo AISI 316L	-	-	-
Tapa superior	Acero Cr-Ni-Mo AISI 316L	-	-	-
Cuerpo de impulsión	Acero Cr-Ni-Mo AISI 316L	Acero Cr-Ni-Mo AISI 316L	Acero Cr-Ni AISI 304	Acero Cr-Ni-Mo AISI 316
Filtro, Válvula completa	Acero Cr-Ni-Mo AISI 316			
Junta válvula	NBR			
Eje	Acero Cr-Ni-Mo AISI 316	Acero Cr-Ni-Mo AISI 316	Acero Cr-Ni-Mo AISI 329	Acero Cr-Ni-Mo AISI 329
Manguito acoplamiento	Acero Cr-Ni-Mo AISI 316/329			
Diffusor	Acero Cr-Ni AISI 304	Acero Cr-Ni-Mo AISI 316L	Acero Cr-Ni AISI 304	Acero Cr-Ni-Mo AISI 316
Cuerpo elemento	Acero Cr-Ni AISI 304	Acero Cr-Ni-Mo AISI 316L	Acero Cr-Ni AISI 304	Acero Cr-Ni-Mo AISI 316
Rodete	Acero Cr-Ni AISI 304	Acero Cr-Ni-Mo AISI 316L	Acero Cr-Ni-Mo AISI 316	Acero Cr-Ni-Mo AISI 316
Anillo de cierre	Teflon (PTFE)			
Cojinete guía	NBR			
Cable cable, Tornillos	Acero Cr-Ni-Mo AISI 316			

Ejecuciones especiales bajo demanda

- Otras tensiones. - Frecuencia 60 Hz.

SX6-13

POMPE SOMMERSE 6"
 6" SUBMERSIBLE PUMPS
 POMPES IMMERGÉES 6"
 BOMBAS SUMERGIDAS 6"

50 Hz - n ≈ 2900 rpm

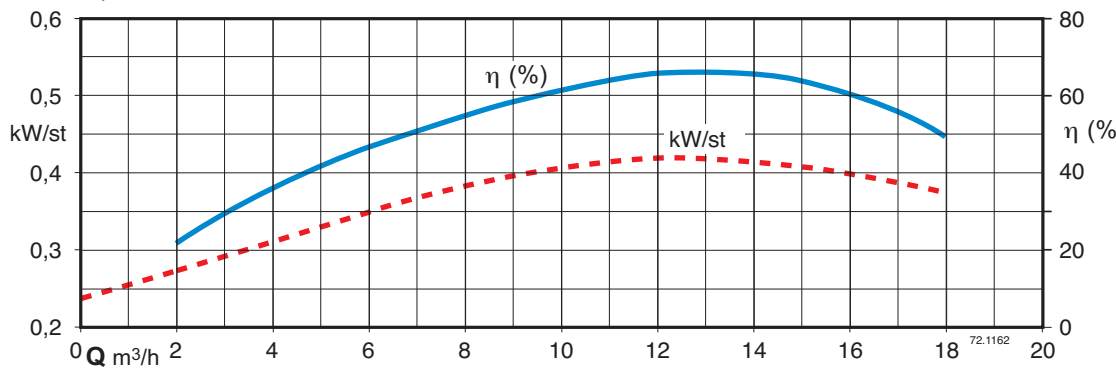
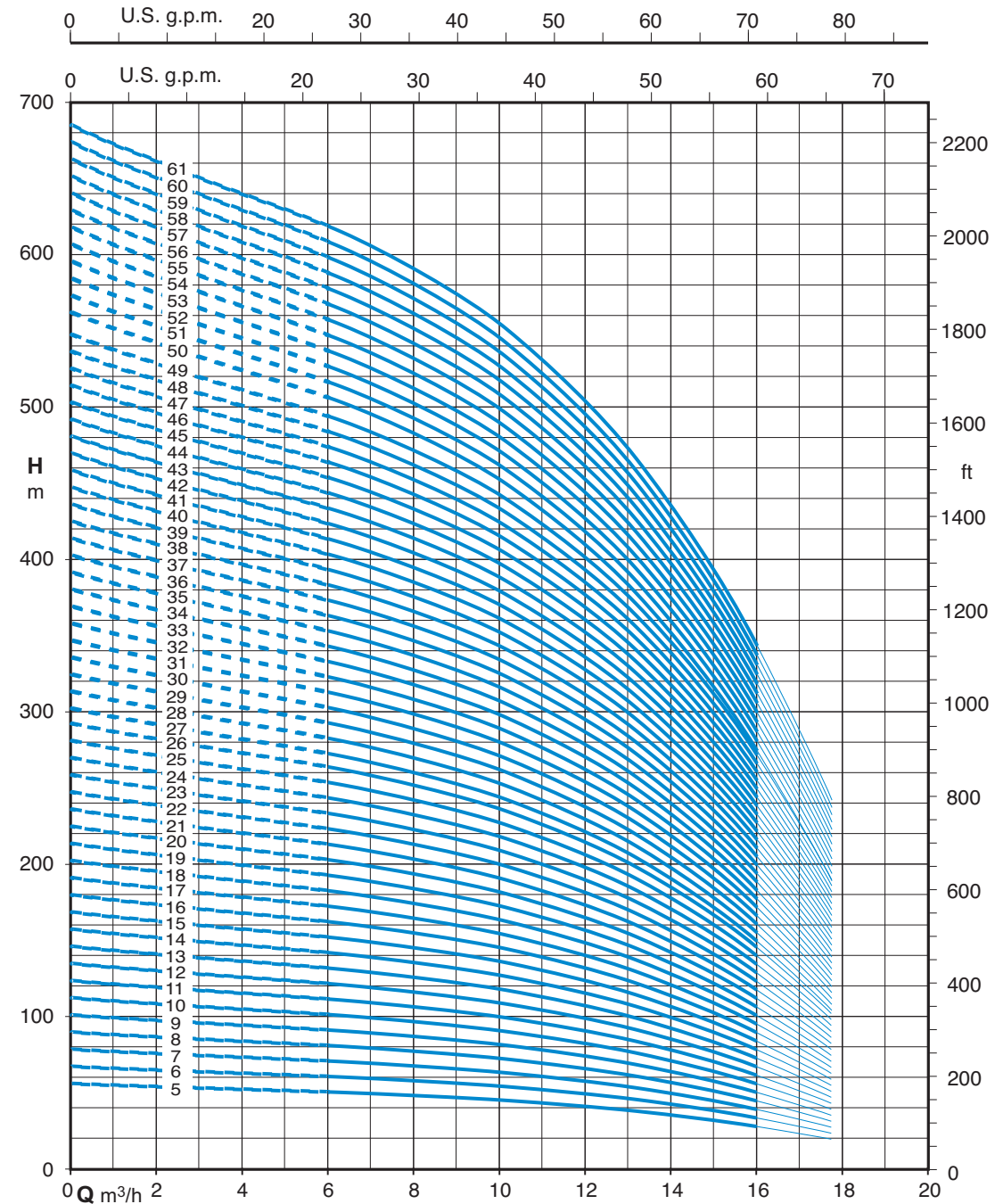

Le dimensioni d'ingombro e i pesi sono indicativi.
 The encumbered dimensions and weight are indicative.
 Les dimensions d'encombrement et les poids sont indicatifs.
 Las dimensiones y los pesos son solamente a título informativo.

SX6-13

POMPE SOMMERSE 6"
6" SUBMERSIBLE PUMPS
POMPES IMMERGÉES 6"
BOMBAS SUMERGIDAS 6"

50 Hz - n ≈ 2900 rpm

TIPO TYPE TYPE	MOTORE MOTOR MOTEUR		Q m³/h l/min	PORTATA - DELIVERY - DEBIT - CAUDAL								DN	MOT. mm	L mm	kg	
	kW	HP		0	6	8	10	12	15	18	-					-
				0	100	133	167	200	250	300	-					-
SX6-13/5	2,2	3	56,1	50,7	48,4	45,4	41,4	31,3	18,6	-	-	414	11,5			
SX6-13/6	3	4	67,3	60,8	58,1	54,5	49,7	37,5	22,3	-	-	444	12,3			
SX6-13/7	3	4	78,5	71,0	67,8	63,6	58,0	43,8	26,0	-	-	474	13			
SX6-13/8	4	5,5	89,7	81,1	77,5	72,7	66,3	50,0	29,7	-	-	501	14			
SX6-13/9	5,5	7,5	101	91,2	87,2	81,8	74,6	56,3	33,4	-	-	531	14,5			
SX6-13/10	5,5	7,5	112	101	96,9	90,9	82,9	62,5	37,1	-	-	561	15			
SX6-13/11	5,5	7,5	123	112	107	100	91,2	68,8	40,8	-	-	591	16			
SX6-13/12	5,5	7,5	135	122	116	109	99,5	75,0	44,6	-	-	621	16,8			
SX6-13/13	5,5	7,5	146	132	126	118	108	81,3	48,3	-	-	651	17,5			
SX6-13/14	7,5	10	157	142	136	127	116	87,5	52,0	-	-	681	18,5			
SX6-13/15	7,5	10	168	152	145	136	124	93,8	55,7	-	-	711	19			
SX6-13/16	7,5	10	179	162	155	145	133	100	59,4	-	-	741	19,8			
SX6-13/17	7,5	10	191	172	165	155	141	106	63,1	-	-	771	20,5			
SX6-13/18	9,2	12,5	202	183	174	164	149	113	66,8	-	-	801	21,3			
SX6-13/19	9,2	12,5	213	193	184	173	158	119	70,5	-	-	831	22			
SX6-13/20	9,2	12,5	224	203	194	182	166	125	74,3	-	-	861	23			
SX6-13/21	9,2	12,5	236	213	203	191	174	131	78,0	-	-	891	23,5			
SX6-13/22	9,2	12,5	247	223	213	200	182	138	81,7	-	-	921	24			
SX6-13/23	11	15	258	233	223	209	191	144	85,4	-	-	951	25			
SX6-13/24	11	15	269	243	233	218	199	150	89,1	-	-	981	25,5			
SX6-13/25	11	15	280	253	242	227	207	156	92,8	-	-	1011	26,5			
SX6-13/26	11	15	292	264	252	236	216	163	96,5	-	-	1041	27			
SX6-13/27	13	17,5	303	274	262	245	224	169	100	-	-	1071	29			
SX6-13/28	13	17,5	314	284	271	255	232	175	104	-	-	1101	29			
SX6-13/29	13	17,5	325	294	281	264	240	181	108	-	-	1131	30,5			
SX6-13/30	13	17,5	336	304	291	273	249	188	111	-	-	1161	30,8			
SX6-13/31	13	17,5	348	314	300	282	257	194	115	-	-	1191	31			
SX6-13/32	15	20	359	324	310	291	265	200	119	-	-	1221	31,5			
SX6-13/33	15	20	370	335	320	300	274	206	123	-	-	1251	32,5			
SX6-13/34	15	20	381	345	329	309	282	213	126	-	-	1281	33,5			
SX6-13/35	15	20	392	355	339	318	290	219	130	-	-	1311	34			
SX6-13/36	15	20	404	365	349	327	298	225	134	-	-	1341	34,5			
SX6-13/37	18,5	25	415	375	358	336	307	231	137	-	-	1371	35,3			
SX6-13/38	18,5	25	426	385	368	345	315	238	141	-	-	1401	36			
SX6-13/39	18,5	25	437	395	378	354	323	244	145	-	-	1431	37,3			
SX6-13/40	18,5	25	449	406	388	364	332	250	149	-	-	1461	38,5			
SX6-13/41	18,5	25	460	416	397	373	340	256	152	-	-	1491	38,8			
SX6-13/42	18,5	25	471	426	407	382	348	263	156	-	-	1521	39			
SX6-13/43	18,5	25	482	436	417	391	356	269	160	-	-	1551	39,8			
SX6-13/44	18,5	25	493	446	426	400	365	275	163	-	-	1581	40,5			
SX6-13/45	22	30	505	456	436	409	373	281	167	-	-	1611	41,3			
SX6-13/46	22	30	516	466	446	418	381	288	171	-	-	1641	42			
SX6-13/47	22	30	527	477	455	427	390	294	175	-	-	1671	43			
SX6-13/48	22	30	538	487	465	436	398	300	178	-	-	1700	44			
SX6-13/49	22	30	549	497	475	445	406	306	182	-	-	1731	45			
SX6-13/50	22	30	561	507	484	454	414	313	186	-	-	1761	46			
SX6-13/51	22	30	572	517	494	464	423	319	189	-	-	1791	47			
SX6-13/52	22	30	583	527	504	473	431	325	193	-	-	1821	48			
SX6-13/53	26	35	594	537	513	482	439	331	197	-	-	1851	48,8			
SX6-13/54	26	35	606	547	523	491	448	338	201	-	-	1881	49,7			
SX6-13/55	26	35	617	558	533	500	456	344	204	-	-	1911	50,5			
SX6-13/56	26	35	628	568	543	509	464	350	208	-	-	1941	51,3			
SX6-13/57	26	35	639	578	552	518	472	356	212	-	-	1971	52,2			
SX6-13/58	26	35	650	588	562	527	481	363	215	-	-	2000	53			
SX6-13/59	26	35	662	598	572	536	489	369	219	-	-	2030	54			
SX6-13/60	26	35	673	608	581	545	497	375	223	-	-	2060	55			
SX6-13/61	26	35	684	618	591	554	506	381	227	-	-	2090	56			

H m
PREVALENZA - HEAD
HAUTEUR MAN. - ALTURA MAN.

DN	MOT. mm	L mm	kg
Rp	145	414	11,5
2"1/2	6"	444	12,3
		474	13
		501	14
		531	14,5
		561	15
		591	16
		621	16,8
		651	17,5
		681	18,5
		711	19
		741	19,8
		771	20,5
		801	21,3
		831	22
		861	23
		891	23,5
		921	24
		951	25
		981	25,5
		1011	26,5
		1041	27
		1071	29
		1101	29
		1131	30,5
		1161	30,8
		1191	31
		1221	31,5
		1251	32,5
		1281	33,5
		1311	34
		1341	34,5
		1371	35,3
		1401	36
		1431	37,3
		1461	38,5
		1491	38,8
		1521	39
		1551	39,8
		1581	40,5
		1611	41,3
		1641	42
		1671	43
		1700	44
		1731	45
		1761	46
		1791	47
		1821	48
		1851	48,8
		1881	49,7
		1911	50,5
		1941	51,3
		1971	52,2
		2000	53
		2030	54
		2060	55
		2090	56

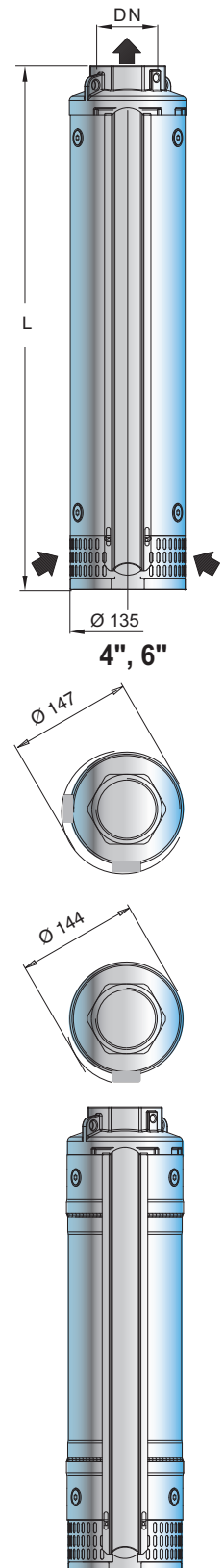

Collare speciale di rinforzo da:
Reinforced with special collar from:
Collier spécial de renforcement à partir:
Collar especial de refuerzo de:
S6X 13/50 (N)

Le dimensioni d'ingombro e i pesi sono indicativi.
The encumbered dimensions and weight are indicative.
Les dimensions d'encombrement et les poids sont indicatifs.
Las dimensiones y los pesos son solamente a título informativo.

SX6-18

POMPE SOMMERSE 6"
6" SUBMERSIBLE PUMPS
POMPES IMMERGÉES 6"
BOMBAS SUMERGIDAS 6"

50 Hz - n ≈ 2900 rpm

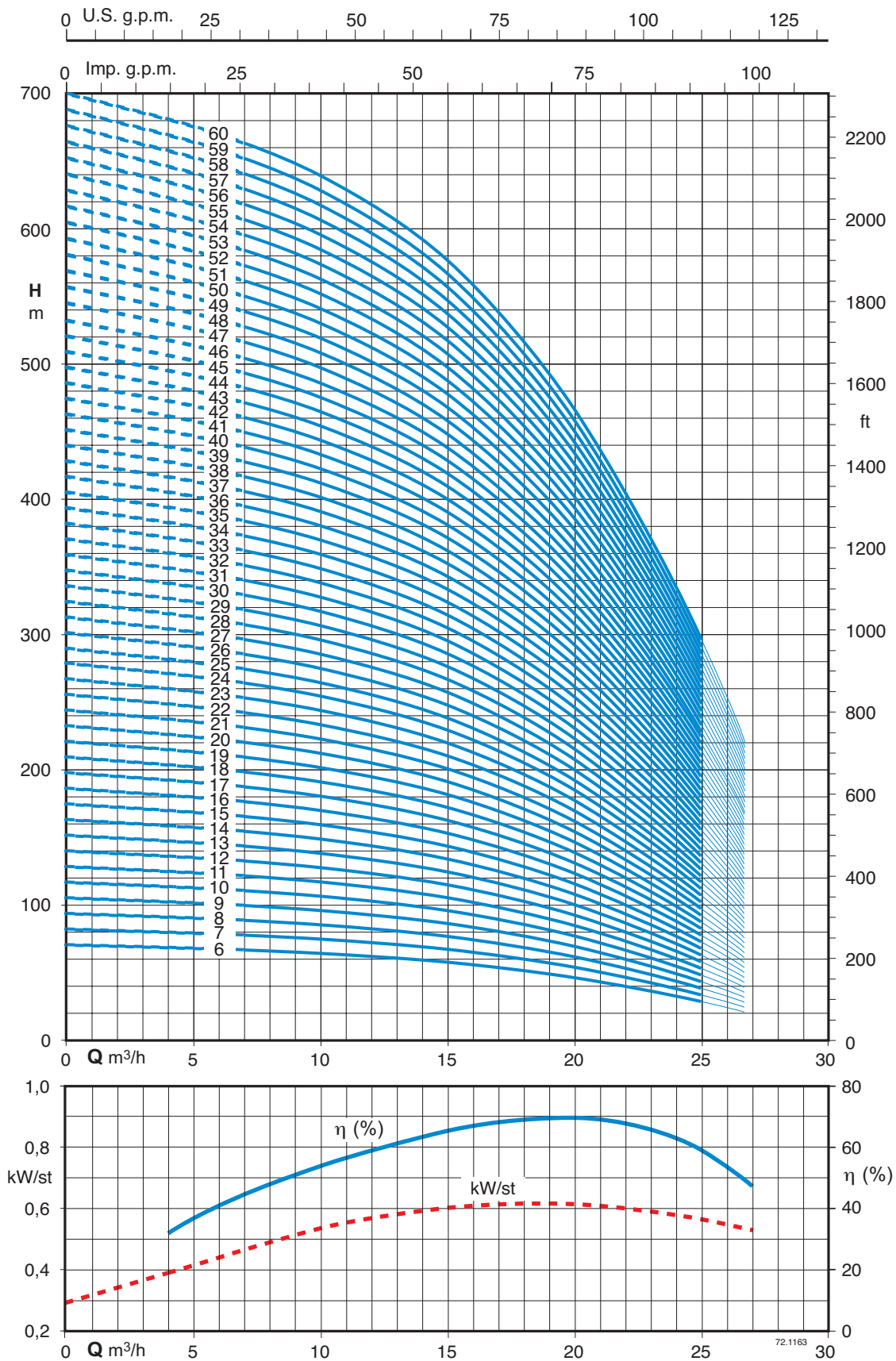

Le dimensioni d'ingombro e i pesi sono indicativi.
The encumbered dimensions and weight are indicative.
Les dimensions d'encombrement et les poids sont indicatifs.
Las dimensiones y los pesos son solamente a título informativo.

SX6-18

POMPE SOMMERSE 6"
6" SUBMERSIBLE PUMPS
POMPES IMMERGÉES 6"
BOMBAS SUMERGIDAS 6"

50 Hz - n ≈ 2900 rpm

TIPO TYPE TYPE	MOTORE MOTOR MOTEUR kW HP		Q m³/h l/min	PORTATA - DELIVERY - DEBIT - CAUDAL										DN	MOT. mm	L mm	kg
				0	8	10	12	15	18	21	24	27					
				0	133	167	200	250	300	350	400	450					
SX6-18/6	4	5,5	70	66,4	64	62	57,6	51,6	43,2	32,9	20,5	494	12,5				
SX6-18/7	5,5	7,5	81,7	77,5	74,7	72,3	67,2	60,2	50,4	38,4	23,9	532	13,5				
SX6-18/8	5,5	7,5	93,3	88,5	85,3	82,7	76,8	68,8	57,6	43,9	27,4	569	14,3				
SX6-18/9	5,5	7,5	105	99,6	96	93	86,4	77,4	64,8	49,4	30,8	607	15				
SX6-18/10	7,5	10	117	111	107	103	96	86	72,0	54,9	34,2	644	16				
SX6-18/11	7,5	10	128	122	117	114	106	94,6	79,2	60,4	37,6	682	17				
SX6-18/12	7,5	10	140	133	128	124	115	103	86,4	65,8	41,0	719	17,5				
SX6-18/13	9,2	12,5	152	144	139	134	125	112	93,6	71,3	44,5	757	18,5				
SX6-18/14	9,2	12,5	163	155	149	145	134	120	101	76,8	47,9	794	19,3				
SX6-18/15	9,2	12,5	175	166	160	155	144	129	108	82,3	51,3	832	20				
SX6-18/16	11	15	187	177	171	165	154	138	115	87,8	54,7	869	21				
SX6-18/17	11	15	198	188	181	176	163	146	122	93,3	58,1	907	22				
SX6-18/18	11	15	210	199	192	186	173	155	130	98,8	61,6	944	22,5				
SX6-18/19	13	17,5	222	210	203	196	182	163	137	104	65,0	982	23,5				
SX6-18/20	13	17,5	233	221	213	207	192	172	144	110	68,4	1019	24				
SX6-18/21	13	17,5	245	232	224	217	202	181	151	115	71,8	1057	25				
SX6-18/22	15	20	257	243	235	227	211	189	158	121	75,2	1094	26				
SX6-18/23	15	20	268	254	245	238	221	198	166	126	78,7	1132	26,5				
SX6-18/24	15	20	280	266	256	248	230	206	173	132	82,1	1169	27,5				
SX6-18/25	18,5	25	292	277	267	258	240	215	180	137	85,5	1207	28,3				
SX6-18/26	18,5	25	303	288	277	269	250	224	187	143	88,9	1244	29				
SX6-18/27	18,5	25	315	299	288	279	259	232	194	148	92,3	1282	31				
SX6-18/28	18,5	25	327	310	299	289	269	241	202	154	95,8	1319	31				
SX6-18/29	18,5	25	338	321	309	300	278	249	209	159	99,2	1356	31,5				
SX6-18/30	18,5	25	350	332	320	310	288	258	216	165	103	1394	32,5				
SX6-18/31	22	30	362	343	331	320	298	267	223	170	106	1431	33,3				
SX6-18/32	22	30	373	354	342	331	307	275	230	176	109	1469	34				
SX6-18/33	22	30	385	365	352	341	317	284	238	181	113	1506	35				
SX6-18/34	22	30	397	376	363	351	326	292	245	187	116	1544	35,7				
SX6-18/35	22	30	408	387	373	362	336	301	252	192	120	1581	36,3				
SX6-18/36	22	30	420	398	384	372	346	310	259	198	123	1619	37				
SX6-18/37	26	35	432	409	395	382	355	318	266	203	127	1656	38,4				
SX6-18/38	26	35	443	420	405	393	365	327	274	209	130	1694	39,8				
SX6-18/39	26	35	455	432	416	403	374	335	281	214	133	1731	40				
SX6-18/40	26	35	467	443	427	413	384	344	288	220	137	1769	40,5				
SX6-18/41	26	35	478	454	437	424	394	353	295	225	140	1806	41,8				
SX6-18/42	26	35	490	465	448	434	403	361	302	230	144	1844	43				
SX6-18/43	30	40	502	476	459	444	413	370	310	236	147	1881	44				
SX6-18/44	30	40	513	487	469	455	422	378	317	241	151	1919	45				
SX6-18/45	30	40	525	498	480	465	432	387	324	247	154	1956	46				
SX6-18/46	30	40	537	509	491	475	442	396	331	252	157	1993	47				
SX6-18/47	30	40	548	520	501	486	451	404	338	258	161	2031	47,5				
SX6-18/48	30	40	560	531	512	496	461	413	346	263	164	2068	48				
SX6-18/49	30	40	572	542	523	506	470	421	353	269	168	2106	50				
SX6-18/50	(37)	(50)	583	553	533	517	480	430	360	274	171	2143	51				
SX6-18/51	(37)	(50)	595	564	544	527	490	439	367	280	174	2181	52				
SX6-18/52	(37)	(50)	607	575	555	537	499	447	374	285	178	2218	53				
SX6-18/53	(37)	(50)	618	586	565	548	509	456	382	291	181	2256	54				
SX6-18/54	(37)	(50)	630	598	576	558	518	464	389	296	185	2293	55				
SX6-18/55	(37)	(50)	642	609	587	568	528	473	396	302	188	2331	56				
SX6-18/56	(37)	(50)	653	620	597	579	538	482	403	307	192	2368	57				
SX6-18/57	(37)	(50)	665	631	608	589	547	490	410	313	195	2406	58				
SX6-18/58	(37)	(50)	677	642	619	599	557	499	418	318	198	2443	59				
SX6-18/59	(37)	(50)	688	653	629	610	566	507	425	324	202	2481	60				
SX6-18/60	(37)	(50)	700	664	640	620	576	516	432	329	205	2518	61				

H m
PREVALENZA - HEAD
HAUTEUR MAN. - ALTURA MAN.

Rp
2"1/2

145
6"

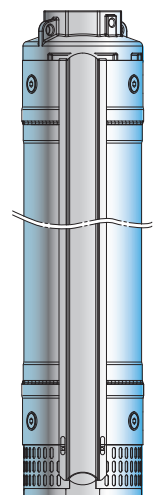
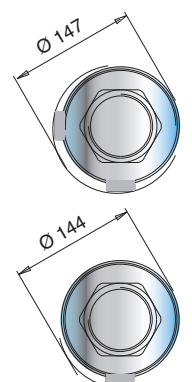
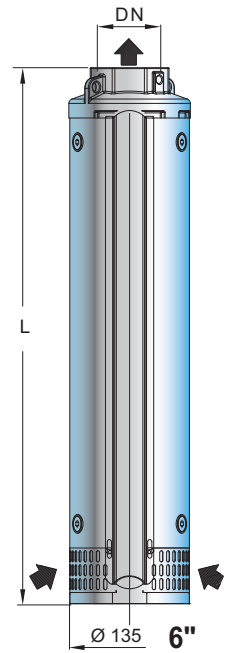

Collare speciale di rinforzo da:
 Reinforced with special collar from:
 Collier spécial de renforcement à partir:
 Collar especial de refuerzo de:
S6X 18/47 (N)

Le dimensioni d'ingombro e i pesi sono indicativi.
 The encumbered dimensions and weight are indicative.
 Les dimensions d'encombrement et les poids sont indicatifs.
 Las dimensiones y los pesos son solamente a título informativo.

SX6-27

POMPE SOMMERSE 6"
 6" SUBMERSIBLE PUMPS
 POMPES IMMERGÉES 6"
 BOMBAS SUMERGIDAS 6"

50 Hz - $n \approx 2900$ rpm

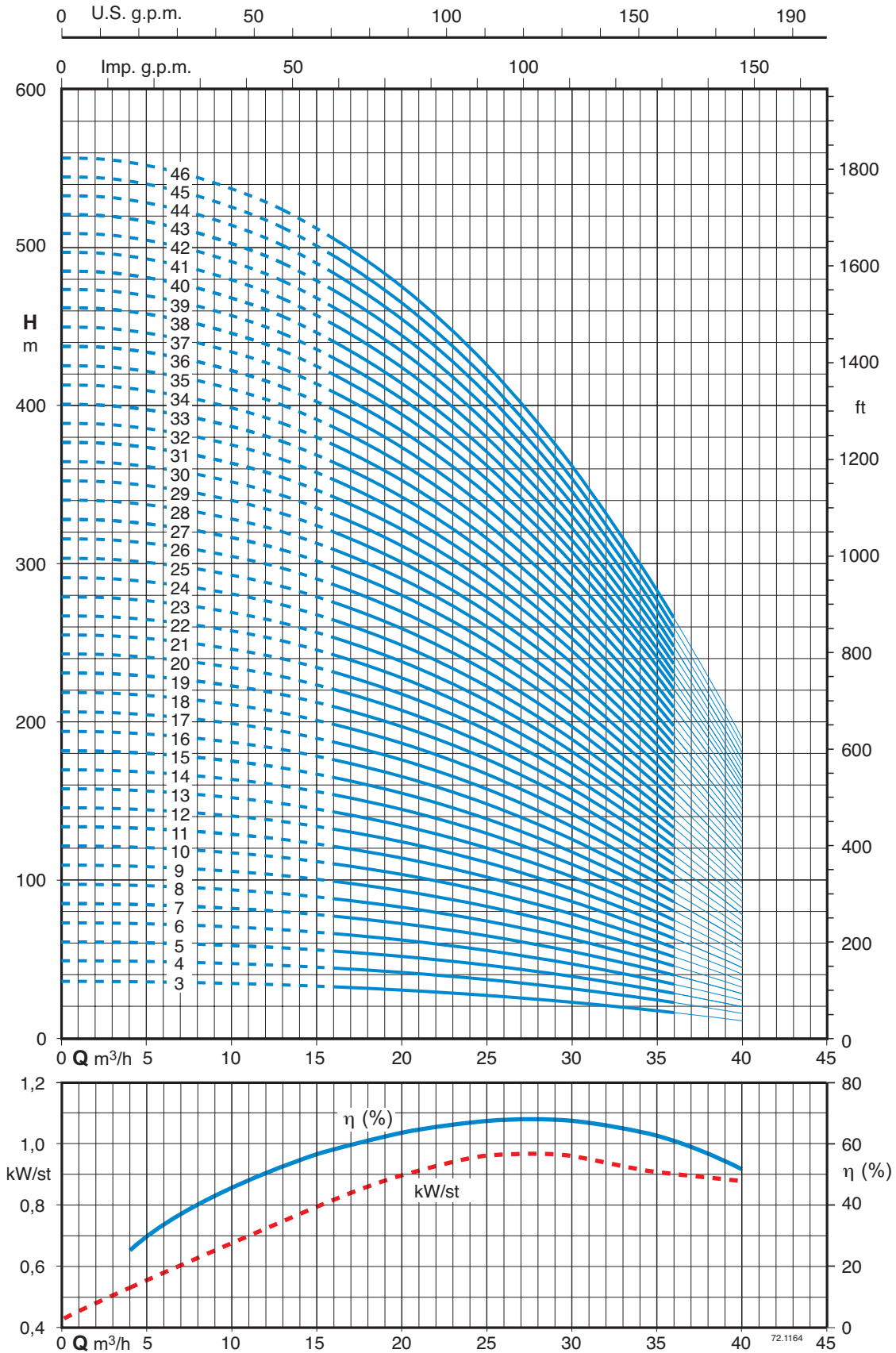

Le dimensioni d'ingombro e i pesi sono indicativi.
 The encumbered dimensions and weight are indicative.
 Les dimensions d'encombrement et les poids sont indicatifs.
 Las dimensiones y los pesos son solamente a título informativo.

SX6-27

POMPE SOMMERSE 6"
6" SUBMERSIBLE PUMPS
POMPES IMMERGÉES 6"
BOMBAS SUMERGIDAS 6"

50 Hz - n ≈ 2900 rpm

TIPO TYPE TYPE	MOTORE MOTOR MOTEUR		Q m ³ /h l/min	PORTATA - DELIVERY - DEBIT - CAUDAL									DN	MOT. mm	L mm	kg
				0	16	20	24	28	32	36	40	-				
				0	266	333	400	466	533	600	666	-				
SX6-27/3	3	4	H m PREVALENZA - HEAD HAUTEUR MAN. - ALTURA MAN.	36,3	32,8	30,7	28,5	25,1	21	17,1	12	-	145 6"	96 - 4"	481	11,5
SX6-27/4	4	5,5		48,4	43,8	41	38,1	33,4	28	22,8	16			524	12,5	
SX6-27/5	5,5	7,5		60,5	54,7	51,2	47,6	41,8	35	28,5	20			571	13,5	
SX6-27/6	7,5	10		72,6	65,7	61,5	57,1	50,1	42	34,2	24			617	14,5	
SX6-27/7	7,5	10		84,7	76,6	71,7	66,6	58,5	49	39,9	28			664	15,5	
SX6-27/8	11	15		96,8	87,5	81,9	76,1	66,9	56	45,6	32			710	16,5	
SX6-27/9	11	15		109	98,5	92,2	85,6	75,2	63	51,3	36			757	17,5	
SX6-27/10	11	15		121	109	102	95,1	83,6	70	57	40			803	19	
SX6-27/11	11	15		133	120	113	105	91,9	77	62,7	44			850	19,5	
SX6-27/12	13	17,5		145	131	123	114	100	84	68,4	48			896	21	
SX6-27/13	13	17,5		157	142	133	124	109	91	74,1	52			943	22,5	
SX6-27/14	15	20		169	153	143	133	117	98	79,8	56			989	22,5	
SX6-27/15	15	20		182	164	154	143	125	105	85,5	60			1036	23	
SX6-27/16	18,5	25		194	175	164	152	134	112	91,2	64			1082	24,5	
SX6-27/17	18,5	25		206	186	174	162	142	119	96,9	68			1129	25	
SX6-27/18	18,5	25		218	197	184	171	150	126	103	72			1175	26	
SX6-27/19	18,5	25		230	208	195	181	159	133	108	76			1222	27	
SX6-27/20	22	30		242	219	205	190	167	140	114	80			1268	28	
SX6-27/21	22	30		254	230	215	200	176	147	120	84			1315	29	
SX6-27/22	22	30		266	241	225	209	184	154	125	88			1361	30	
SX6-27/23	22	30		278	252	236	219	192	161	131	92			1408	31	
SX6-27/24	26	35		290	263	246	228	201	168	137	96			1454	32	
SX6-27/25	26	35		303	274	256	238	209	175	143	100			1500	33	
SX6-27/26	26	35		315	285	266	247	217	182	148	104			1547	35	
SX6-27/27	26	35		327	296	277	257	226	189	154	108			1593	35	
SX6-27/28	30	40		339	306	287	266	234	196	160	112			1640	36	
SX6-27/29	30	40		351	317	297	276	242	203	165	116			1686	37	
SX6-27/30	30	40		363	328	307	285	251	210	171	120			1733	38	
SX6-27/31	30	40		375	339	318	295	259	217	177	124			1779	39	
SX6-27/32	(37)	(50)		387	350	328	305	267	224	182	128			1826	40	
SX6-27/33	(37)	(50)		399	361	338	314	276	231	188	132			1872	41	
SX6-27/34	(37)	(50)		411	372	348	324	284	238	194	136			1919	42	
SX6-27/35	(37)	(50)		424	383	359	333	293	245	200	140			1965	43	
SX6-27/36	(37)	(50)		436	394	369	343	301	252	205	144			2012	44	
SX6-27/37	(37)	(50)		448	405	379	352	309	259	211	148			2058	44,8	
SX6-27/38	(37)	(50)		460	416	389	362	318	266	217	152			2105	45,5	
SX6-27/39	(45)	(60)		472	427	400	371	326	273	222	156			2151	46,8	
SX6-27/40	(45)	(60)		484	438	410	381	334	280	228	160			2197	48	
SX6-27/41	(45)	(60)		496	449	420	390	343	287	234	164			2244	49	
SX6-27/42	(45)	(60)		508	460	430	400	351	294	239	168			2290	50	
SX6-27/43	(45)	(60)		520	471	440	409	359	301	245	172			2337	51	
SX6-27/44	(45)	(60)		532	482	451	419	368	308	251	176			2383	52	
SX6-27/45	(45)	(60)		545	492	461	428	376	315	257	180			2430	53	
SX6-27/46	(45)	(60)		557	503	471	438	384	322	262	184			2476	54	

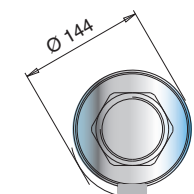
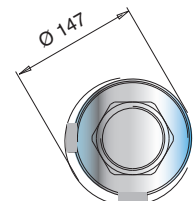
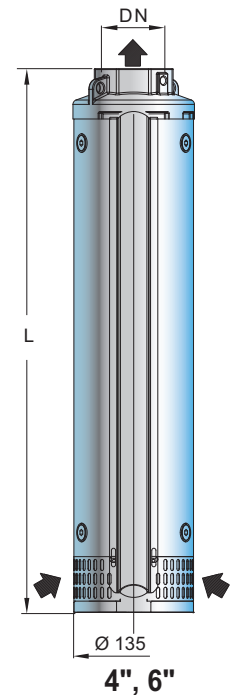

Le dimensioni d'ingombro e i pesi sono indicativi.
 The encumbered dimensions and weight are indicative.
 Les dimensions d'encombrement et les poids sont indicatifs.
 Las dimensiones y los pesos son solamente a título informativo.

SX6-30

POMPE SOMMERSE 6"
 6" SUBMERSIBLE PUMPS
 POMPES IMMERGÉES 6"
 BOMBAS SUMERGIDAS 6"

50 Hz - $n \approx 2900$ rpm

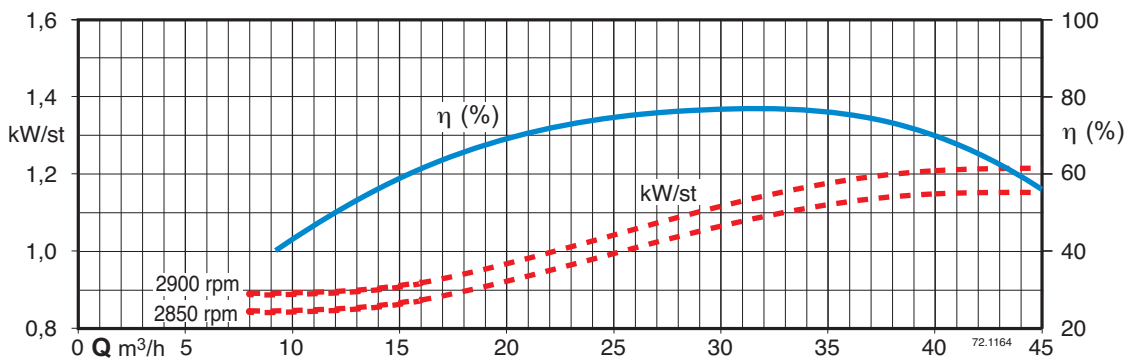
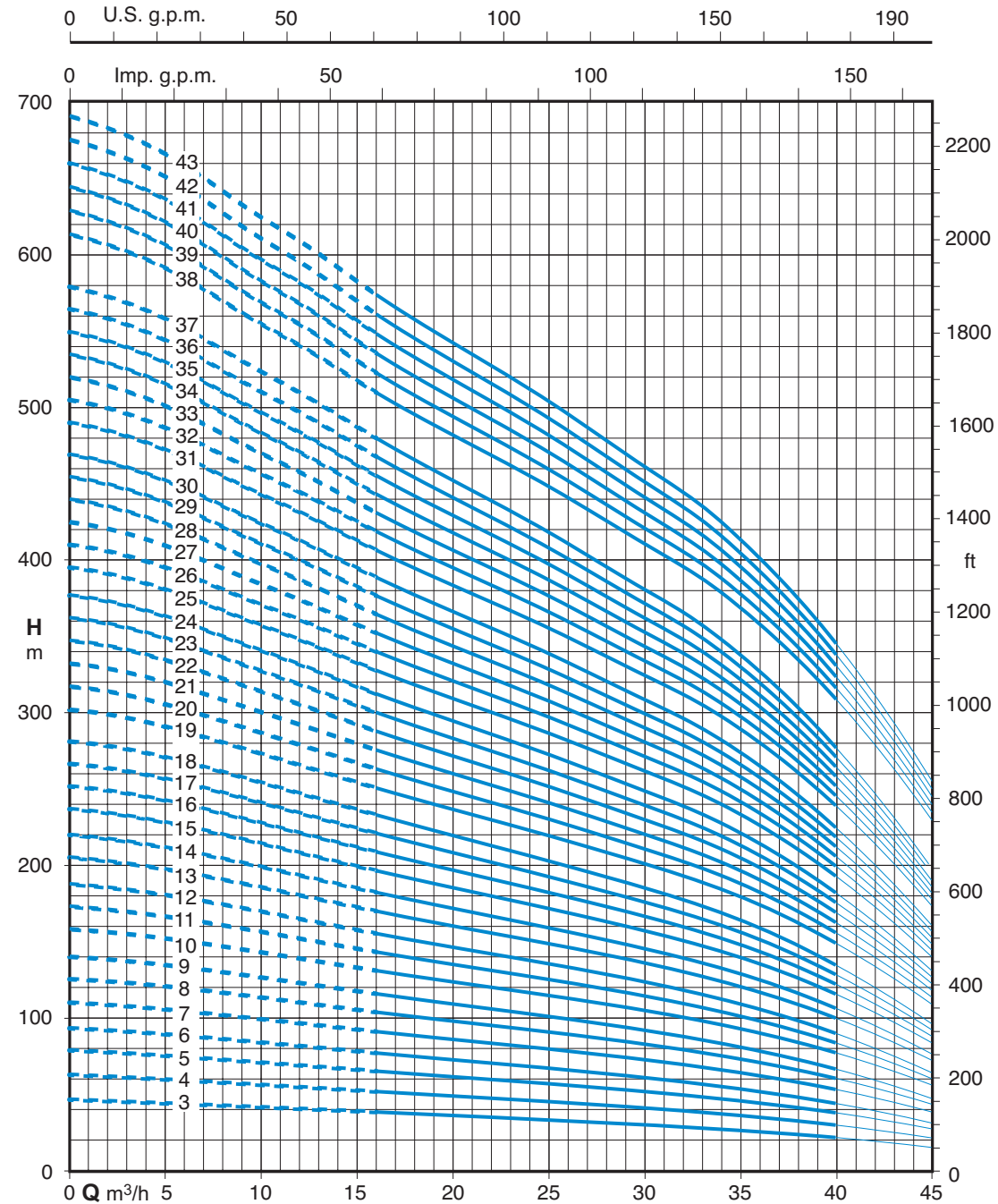

Le dimensioni d'ingombro e i pesi sono indicativi.
 The encumbered dimensions and weight are indicative.
 Les dimensions d'encombrement et les poids sont indicatifs.
 Las dimensiones y los pesos son solamente a título informativo.

SX6-30

POMPE SOMMERSE 6"
6" SUBMERSIBLE PUMPS
POMPES IMMERGÉES 6"
BOMBAS SUMERGIDAS 6"

50 Hz - n ≈ 2900 rpm

TIPO TYPE TYPE	MOTORE MOTOR MOTEUR		Q m³/h l/min	PORTATA - DELIVERY - DEBIT - CAUDAL										DN	MOT. mm	L mm	kg
	kW	HP		0	15	20	25	30	35	40	45	-					
				0	250	333	416	500	583	666	750	-					
SX6-30/3	4	5,5	H m PREVALENZA - HEAD HAUTEUR MAN. - ALTURA MAN.	46,3	38,9	36	33,3	30,2	26,7	21,7	15,3	-	Rp 3"	145 6"	620	14,7	
SX6-30/4	5,5	7,5		62,5	52,6	48,8	45,2	41,1	36,5	30	21,4	-			705	16,8	
SX6-30/5	7,5	10		78,6	66,2	61,5	56,9	51,8	46,1	38	27,4	-			790	18,9	
SX6-30/6	7,5	10		93,1	78,4	72,6	67,1	61	54	44,1	31,2	-			876	21	
SX6-30/7	9,2	12,5		110	92,6	86	79,7	72,6	64,6	53,3	38,4	-			961,5	23,1	
SX6-30/8	11	15		125	106	98,1	90,9	82,7	73,6	60,5	43,5	-			1047	25,4	
SX6-30/9	11	15		140	118	109	101	91,8	81,4	66,6	47,3	-			1132	27,3	
SX6-30/10	13	17,5		158	133	124	115	105	93,5	77,3	56,1	-			1218	29,4	
SX6-30/11	15	20		173	146	135	125	114	102	83,8	60,4	-			1303	31,5	
SX6-30/12	15	20		188	158	147	136	123	110	90	64,4	-			1389	33,6	
SX6-30/13	18,5	25		205	173	161	149	136	121	100	72,4	-			1474	35,7	
SX6-30/14	18,5	25		220	185	172	159	145	129	106	76,7	-			1560	37,8	
SX6-30/15	22	30		237	200	185	172	157	140	116	84	-			1645	39,9	
SX6-30/16	22	30		252	212	197	183	166	148	122	88,3	-			1730	42	
SX6-30/17	22	30		267	224	208	193	176	156	129	92,5	-			1816	44,1	
SX6-30/18	22	30		281	237	220	203	185	164	135	96,5	-			1901	46,1	
SX6-30/19	26	35		302	255	237	220	201	180	149	109	-			1987	48,2	
SX6-30/20	26	35		317	267	249	231	210	188	156	114	-			2072	50,3	
SX6-30/21	26	35		332	280	260	241	220	197	163	118	-			2157	52,4	
SX6-30/22	30	40		347	293	272	252	230	205	169	123	-			2243	54,5	
SX6-30/23	30	40		362	305	283	263	239	213	176	127	-			2328	56,6	
SX6-30/24	30	40		377	317	295	273	249	221	182	131	-			2414	58,7	
SX6-30/25	37	50		395	333	309	287	261	233	193	140	-			2499	60,8	
SX6-30/26	37	50		410	345	321	297	271	242	200	144	-			2584	62,9	
SX6-30/27	37	50		425	358	332	308	280	250	206	149	-			2670	65	
SX6-30/28	37	50		440	370	344	318	290	258	212	153	-			2755	67,2	
SX6-30/29	37	50		454	383	355	329	299	266	219	157	-			2840	69,2	
SX6-30/30	37	50		469	395	366	339	308	274	225	161	-			2926	71,3	
SX6-30/31	45	60		490	413	384	356	324	289	239	174	-			3011	75,2	
SX6-30/32	45	60		505	425	395	366	334	298	246	178	-			3096	78,3	
SX6-30/33	45	60		520	438	407	377	343	306	252	182	-			3182	80,4	
SX6-30/34	45	60		535	450	418	387	353	314	259	186	-			3267	82,5	
SX6-30/35	45	60		549	463	429	398	362	322	265	190	-			3352	84,6	
SX6-30/36	45	60		564	475	441	408	371	330	271	194	-			3438	87,9	
SX6-30/37	45	60		579	487	452	418	380	338	277	198	-			3523	90	
SX6-30/38	51	70		613	517	482	448	410	369	309	229	-			3709	92,3	
SX6-30/39	51	70		628	530	494	459	420	378	316	234	-			3794	94,5	
SX6-30/40	51	70		644	543	506	471	430	387	323	240	-			3879	96,6	
SX6-30/41	51	70		659	557	518	482	440	396	330	245	-			3965	97,6	
SX6-30/42	55	75		675	569	530	493	450	404	338	250	-			4050	98,7	
SX6-30/43	55	75		690	582	542	504	460	413	345	255	-			4135	99,8	

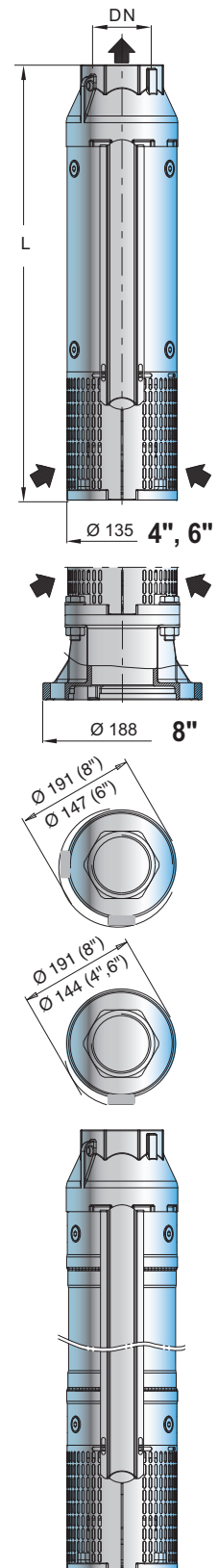

Collare speciale di rinforzo da:
Reinforced with special collar from:
Collier spécial de renforcement à partir:
Collar especial de refuerzo de:
S6X 30/36 (N)

Le dimensioni d'ingombro e i pesi sono indicativi.
The encumbered dimensions and weight are indicative.
Les dimensions d'encombrement et les poids sont indicatifs.
Las dimensiones y los pesos son solamente a título informativo.

SX6-46

POMPE SOMMERSE 6"
6" SUBMERSIBLE PUMPS
POMPES IMMERGÉES 6"
BOMBAS SUMERGIDAS 6"

50 Hz - $n \approx 2900$ rpm

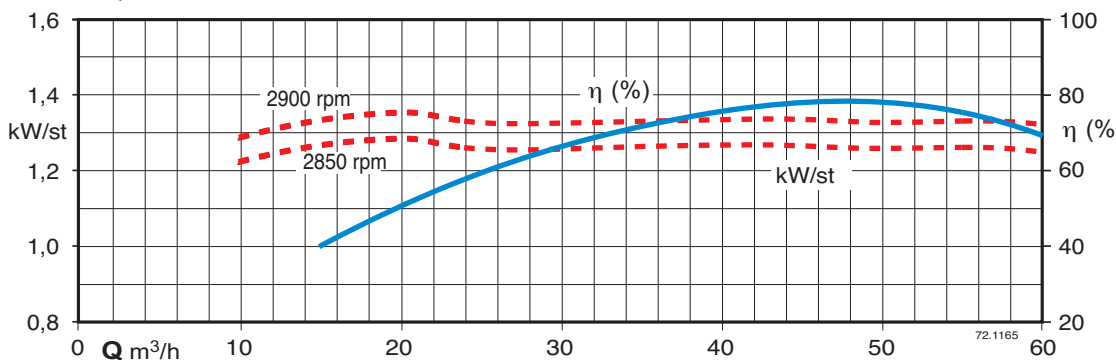
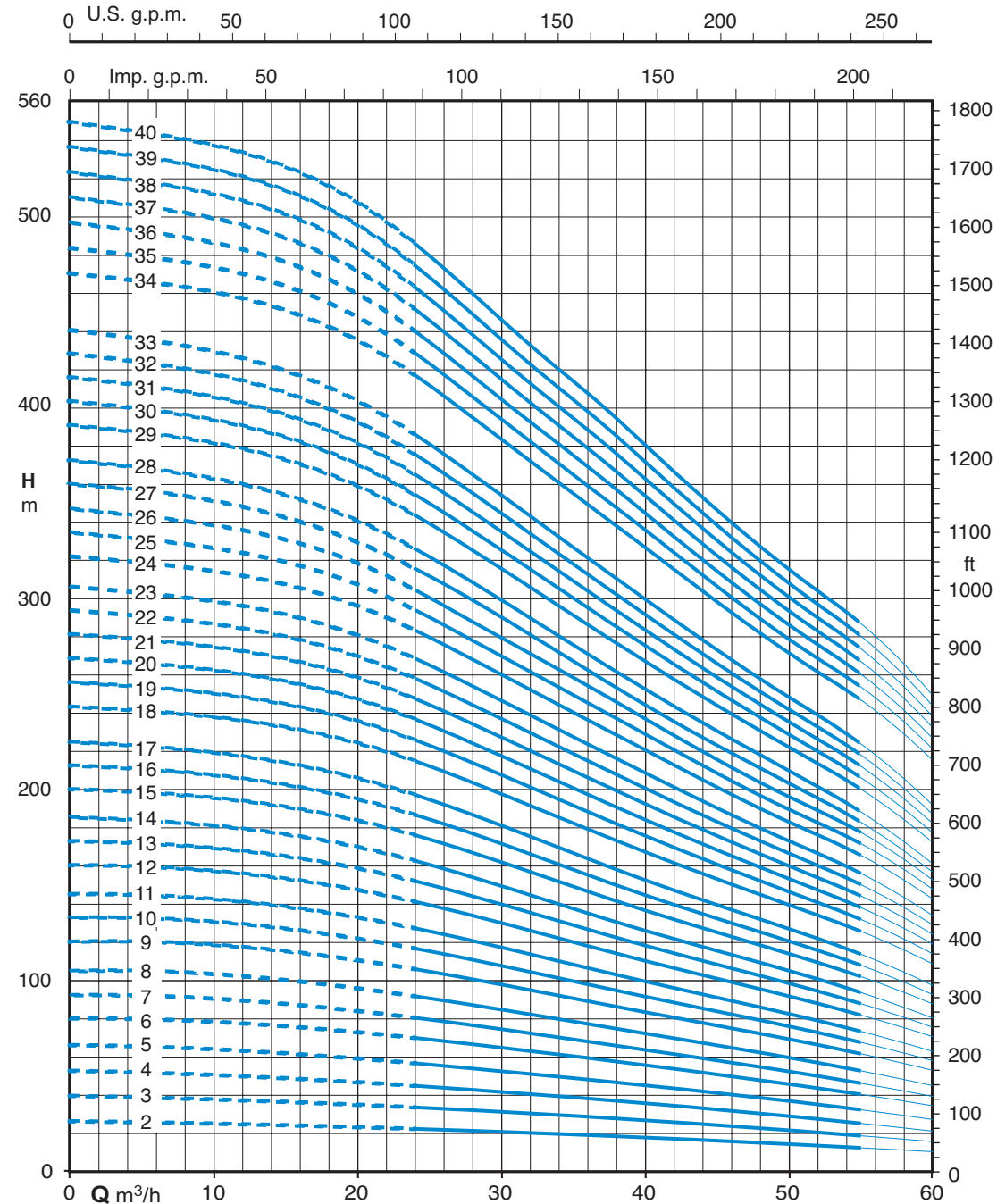

Le dimensioni d'ingombro e i pesi sono indicativi.
The encumbered dimensions and weight are indicative.
Les dimensions d'encombrement et les poids sont indicatifs.
Las dimensiones y los pesos son solamente a titulo informativo.

SX6-46

POMPE SOMMERSE 6"
6" SUBMERSIBLE PUMPS
POMPES IMMERGÉES 6"
BOMBAS SUMERGIDAS 6"

50 Hz - n ≈ 2900 rpm

TIPO TYPE TYPE	MOTORE MOTOR MOTEUR		Q m ³ /h l/min	PORTATA - DELIVERY - DEBIT - CAUDAL											DN mm	MOT. mm	L mm	kg
	kW	HP		0	25	30	35	40	45	50	55	60	-	-				
				0	416	500	583	666	750	833	916	1000	-	-				
SX6-46/2	3	4	26,4	22,6	20,9	19,3	17,8	16,6	15,1	13,4	11,3	-	-	96 - 4"	594	13,5		
SX6-46/3	4	5,5	39,4	33,8	31,2	28,8	26,6	24,7	22,5	19,9	16,8	-	-	145 6"	705	16,2		
SX6-46/4	5,5	7,5	52,5	45	41,5	38,3	35,5	32,9	29,9	26,5	22,3	-	-		819	18,8		
SX6-46/5	7,5	10	66,1	56,8	52,3	48,3	44,7	41,5	37,8	33,6	28,4	-	-		933	21,4		
SX6-46/6	9,2	12,5	80,7	70	65,2	60,4	55,5	50,3	46	41,6	35,7	-	-		1047	24,0		
SX6-46/7	9,2	12,5	93,1	80,4	74,8	69,3	63,5	57,6	52,7	47,5	40,5	-	-		1161	26,6		
SX6-46/8	11	15	106	91,6	85,1	78,9	72,2	65,5	59,9	54	46	-	-		1275	29,2		
SX6-46/9	13	17,5	121	105	98,2	91	83,7	75,9	69,5	62,9	54,1	-	-		1389	31,8		
SX6-46/10	13	17,5	134	116	108	100	91,9	83,3	76,2	68,9	59	-	-		1503	34,4		
SX6-46/11	15	20	146	126	118	109	99,9	90,5	82,8	74,7	63,7	-	-		1617	37,0		
SX6-46/12	18,5	25	161	140	130	12	111	101	92	83,3	71,4	-	-		1730	39,6		
SX6-46/13	18,5	25	174	150	140	130	119	108	98,7	89,2	76,3	-	-		1844	42,2		
SX6-46/14	18,5	25	186	161	149	139	127	115	105	95	81	-	-	1958	44,8			
SX6-46/15	22	30	201	174	162	150	138	125	114	103	88,4	-	-	2072	47,4			
SX6-46/16	22	30	213	184	171	159	146	132	121	109	93,2	-	-	2186	50,1			
SX6-46/17	22	30	225	195	181	168	154	139	127	115	97,8	-	-	2300	52,7			
SX6-46/18	26	35	244	212	198	183	169	153	140	127	109	-	-	2414	55,3			
SX6-46/19	26	35	257	223	208	192	177	160	147	133	114	-	-	2527	57,9			
SX6-46/20	30	40	269	234	218	208	185	168	154	139	119	-	-	2641	60,5			
SX6-46/21	30	40	282	244	227	211	193	175	160	145	124	-	-	2755	63,1			
SX6-46/22	30	40	294	255	237	220	202	183	167	151	129	-	-	2869	65,7			
SX6-46/23	30	40	307	265	247	229	209	190	174	157	134	-	-	2983	68,3			
SX6-46/24	37	50	322	280	260	241	222	201	184	166	143	-	-	3096	70,9			
SX6-46/25	37	50	335	290	270	250	230	208	191	172	147	-	-	3210	73,5			
SX6-46/26	37	50	347	301	280	259	238	216	197	178	152	-	-	3324	76,1			
SX6-46/27	37	50	360	311	289	268	246	223	204	184	157	-	-	3438	79,3			
SX6-46/28	37	50	372	321	299	277	254	230	210	190	162	-	-	3552	82,0			
SX6-46/29	45	60	390	339	315	292	268	243	223	201	173	-	-	3665	87,4			
SX6-46/30	45	60	403	349	325	301	276	251	229	207	178	-	-	3779	90,0			
SX6-46/31	45	60	415	360	334	310	284	258	236	213	183	-	-	3893	92,6			
SX6-46/32	45	60	427	370	344	319	292	265	243	219	187	-	-	4007	95,2			
SX6-46/33	45	60	440	380	353	328	300	272	249	225	192	-	-	4121	97,8			
SX6-46/34	51	70	469	411	383	355	328	298	272	248	216	-	-	4335	101			
SX6-46/35	51	70	482	422	394	365	337	306	279	255	221	-	-	4449	103			
SX6-46/36	51	70	496	434	404	374	346	314	287	261	227	-	-	4562	106			
SX6-46/37	51	70	509	445	415	384	355	322	294	268	233	-	-	4676	109			
SX6-46/38	55	75	522	456	425	394	364	330	302	275	238	-	-	4790	111			
SX6-46/39	55	75	535	467	436	403	372	338	309	281	244	-	-	4904	114			
SX6-46/40	55	75	548	479	446	413	381	346	316	288	249	-	-	5018	117			

H m
PREVALENZA - HEAD
HAUTEUR MAN. - ALTURA MAN.

DN	MOT.	L	kg
mm	mm	mm	kg
96 - 4"	594	13,5	
145 6"	705	16,2	
	819	18,8	
	933	21,4	
	1047	24,0	
	1161	26,6	
	1275	29,2	
	1389	31,8	
	1503	34,4	
	1617	37,0	
	1730	39,6	
	1844	42,2	
Rp 3"	1958	44,8	
	2072	47,4	
	2186	50,1	
	2300	52,7	
	2414	55,3	
	2527	57,9	
	2641	60,5	
	2755	63,1	
	2869	65,7	
	2983	68,3	
	3096	70,9	
191 8"	3210	73,5	
	3324	76,1	
	3438	79,3	
	3552	82,0	
	3665	87,4	
	3779	90,0	
	3893	92,6	
	4007	95,2	
	4121	97,8	
	4335	101	
	4449	103	
4562	106		
4676	109		
4790	111		
4904	114		
5018	117		

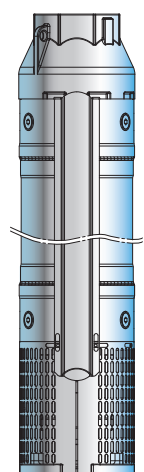
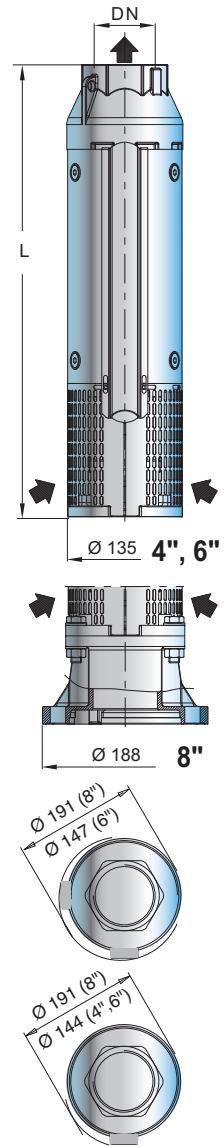

Collare speciale di rinforzo da:
 Reinforced with special collar from:
 Collier spécial de renforcement à partir de:
 Collar especial de refuerzo de:
S6X 46/27 (N)

Le dimensioni d'ingombro e i pesi sono indicativi.
 The encumbered dimensions and weight are indicative.
 Les dimensions d'encombrement et les poids sont indicatifs.
 Las dimensiones y los pesos son solamente a título informativo.

SX6-65

POMPE SOMMERSE 6"
 6" SUBMERSIBLE PUMPS
 POMPES IMMERGÉES 6"
 BOMBAS SUMERGIDAS 6"

50 Hz - $n \approx 2900$ rpm

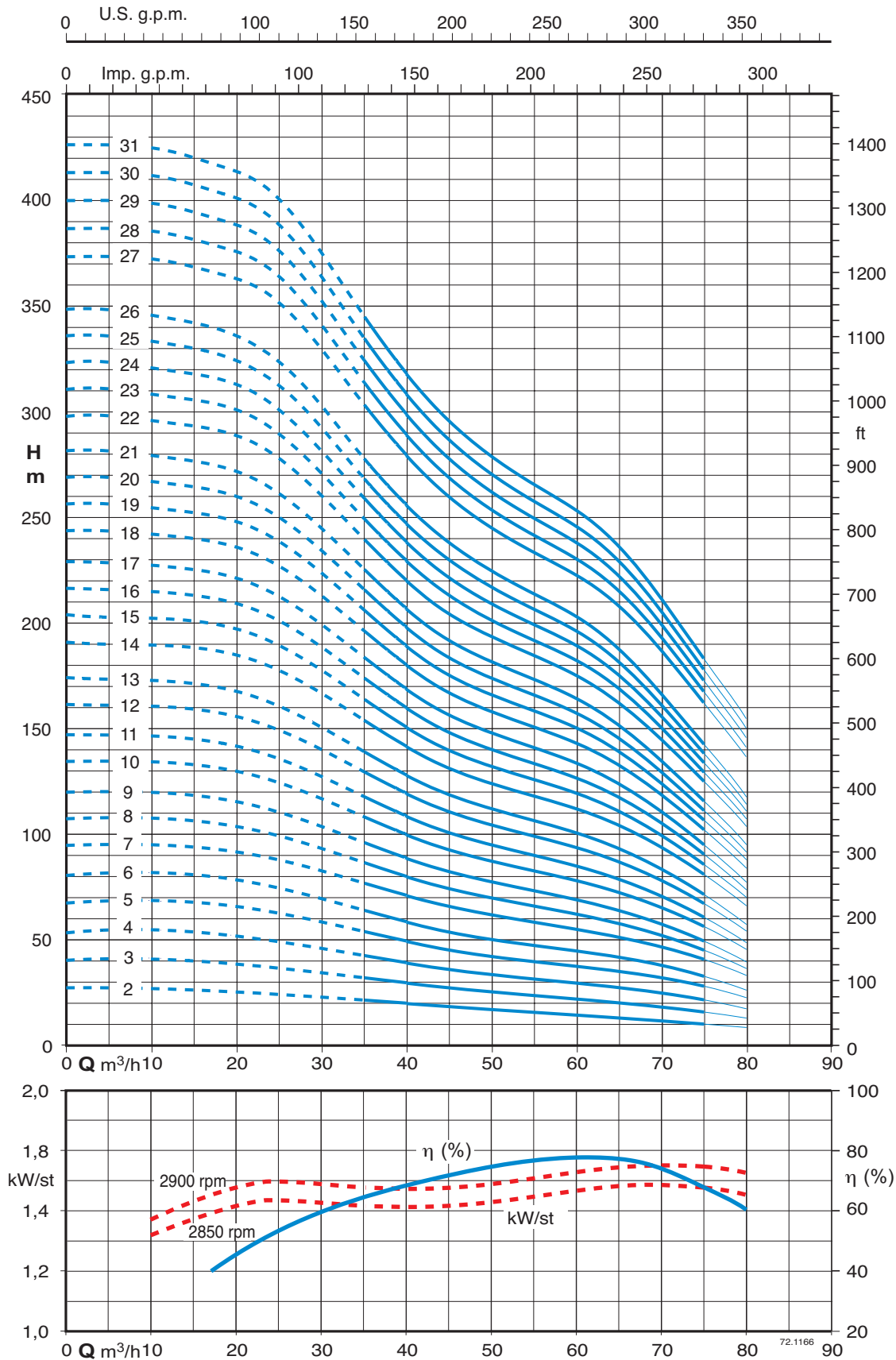

Le dimensioni d'ingombro e i pesi sono indicativi.
 The encumbered dimensions and weight are indicative.
 Les dimensions d'encombrement et les poids sont indicatifs.
 Las dimensiones y los pesos son solamente a titulo informativo.

SX6-65

POMPE SOMMERSE 6"
6" SUBMERSIBLE PUMPS
POMPES IMMERGÉES 6"
BOMBAS SUMERGIDAS 6"

50 Hz - n ≈ 2900 rpm

TIPO TYPE TYPE	MOTORE MOTOR MOTEUR kW HP		Q m³/h l/min	PORTATA - DELIVERY - DEBIT - CAUDAL											DN	MOT. mm	L mm	kg
				0	35	40	45	50	55	60	65	70	75	80				
				0	583	666	750	833	916	1000	1083	1166	1250	1333				
SX6-65/2	4	5,5	26,8	21,1	19	17,3	16,5	15,7	14,9	13,9	12,4	10,5	8,2	592	13,6			
SX6-65/3	5,5	7,5	40,4	31,8	28,8	26,2	24,9	23,7	22,5	21	18,9	16	12,6	705	16,2			
SX6-65/4	7,5	10	54	42,5	38,4	35	33,2	31,6	30,1	28	25,2	21,4	16,9	819	18,8			
SX6-65/5	9,2	12,5	68	53,8	48,7	44,3	41,9	40,1	38,2	35,6	32,2	27,5	22	933	21,4			
SX6-65/6	11	15	81,2	64	57,9	52,7	50	47,7	45,3	42,3	38,1	32,3	25,7	1047	24,0			
SX6-65/7	13	17,5	94,9	76,2	70,1	65,2	61,7	58,6	55,7	52,1	46,1	39,7	33,4	1161	26,7			
SX6-65/8	15	20	108	86	79,1	73,5	69,7	66,1	62,8	58,5	51,6	44,3	37	1275	29,3			
SX6-65/9	15	20	120	95,5	87,8	81,5	77,4	73,4	69,6	64,6	56,8	48,6	40,2	1389	31,9			
SX6-65/10	18,5	25	134	108	99	91,9	87,2	82,7	78,5	73,2	64,6	55,5	46,3	1503	34,5			
SX6-65/11	18,5	25	147	117	108	100	95	90	85,4	79,4	69,8	59,9	49,6	1617	37,1			
SX6-65/12	22	30	161	129	118	110	104	99,1	94,1	87,6	77,3	66,3	55,3	1730	39,7			
SX6-65/13	22	30	174	138	127	118	112	106	101	93,8	82,5	70,8	58,6	1844	42,4			
SX6-65/14	26	35	190	153	141	131	124	118	112	105	93	80,2	67,7	1958	44,9			
SX6-65/15	26	35	203	163	150	140	132	126	119	111	98,7	85	71,5	2072	47,5			
SX6-65/16	30	40	216	173	159	148	140	133	126	118	104	89,7	75,2	2186	50,2			
SX6-65/17	30	40	229	183	168	156	148	141	133	124	110	94,3	78,8	2300	52,8			
SX6-65/18	37	50	243	195	180	167	158	150	143	133	118	101	85,2	2414	55,4			
SX6-65/19	37	50	256	205	189	175	166	158	150	140	123	106	88,9	2527	58,0			
SX6-65/20	37	50	269	215	198	184	174	165	157	146	129	111	92,4	2641	60,7			
SX6-65/21	37	50	281	225	206	192	182	173	164	152	134	115	95,7	2755	63,3			
SX6-65/22	45	60	298	239	220	204	194	184	175	163	144	124	104	2869	68,7			
SX6-65/23	45	60	310	249	229	213	202	191	182	170	150	129	108	2983	71,3			
SX6-65/24	45	60	323	259	238	221	209	199	189	176	155	133	111	3096	73,9			
SX6-65/25	45	60	336	268	247	229	217	206	196	182	161	138	115	3210	76,5			
SX6-65/26	45	60	348	278	255	237	225	213	202	188	166	142	118	3324	79,1			
SX6-65/27	51	70	373	303	279	259	245	233	222	208	186	162	137	3538	82,6			
SX6-65/28	51	70	386	313	288	268	253	241	229	216	193	167	142	3652	85,3			
SX6-65/29	51	70	399	324	298	277	262	249	237	223	199	172	146	3765	87,9			
SX6-65/30	55	75	413	334	308	286	270	258	245	230	205	177	151	3879	90,5			
SX6-65/31	55	75	426	345	317	295	279	265	252	237	211	183	155	3993	93,2			

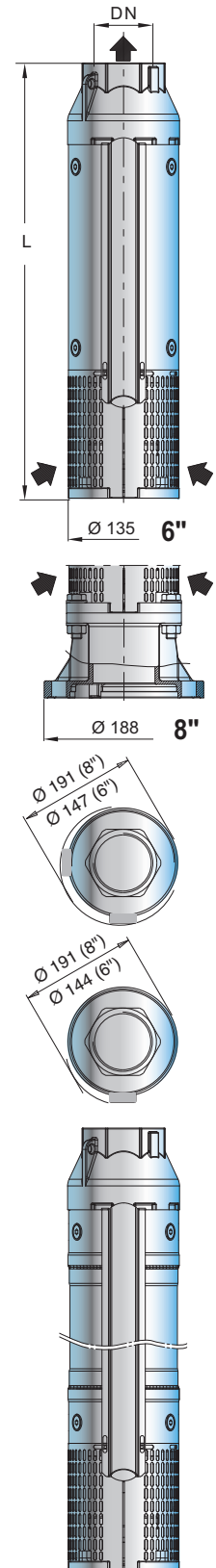

Collare speciale di rinforzo da:
Reinforced with special collar from:
Collier spécial de renforcement à partir:
Collar especial de refuerzo de:
S6X 65/27 (N)

Le dimensioni d'ingombro e i pesi sono indicativi.
The encumbered dimensions and weight are indicative.
Les dimensions d'encombrement et les poids sont indicatifs.
Las dimensiones y los pesos son solamente a título informativo.

SX8-78

POMPE SOMMERSE 8"
8" SUBMERSIBLE PUMPS
POMPES IMMERGÉES 8"
BOMBAS SUMERGIDAS 8"

50 Hz - n ≈ 2900 rpm

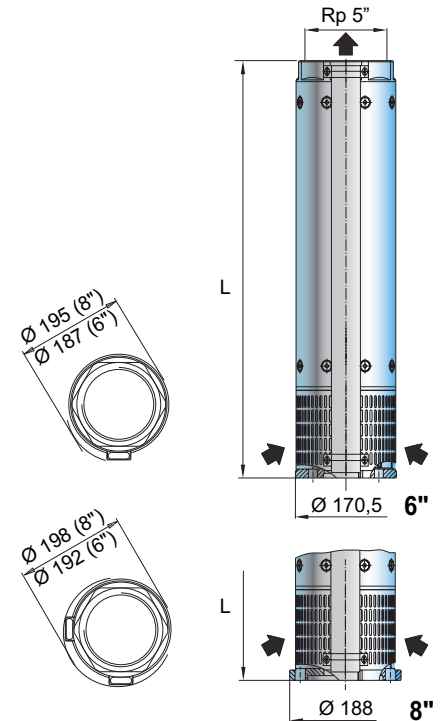
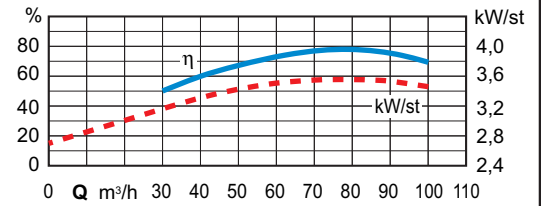
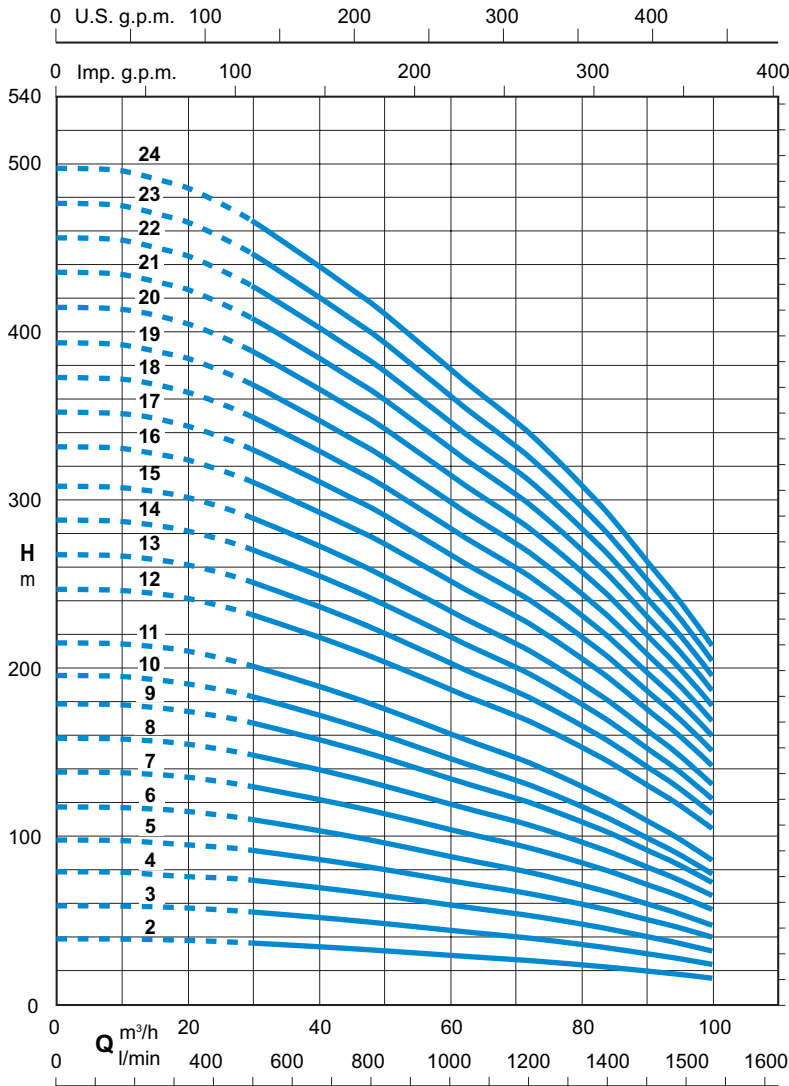

TIPO TYPE TYPE	MOTORE MOTOR MOTEUR		Q m³/h l/min	PORTATA - DELIVERY - DEBIT - CAUDAL																		
	kW	HP		H m																		
				0	30	40	50	60	70	80	90	100										
SX8-78/2N	7,5	10	39,9	37,1	34,9	32,6	29,7	27,1	24,3	20,4	16,3											
SX8-78/3N	11	15	59,8	55,7	52,3	48,9	44,6	40,7	36,4	30,6	24,4											
SX8-78/4N	15	20	79,7	74,3	69,7	65,1	59,4	54,3	48,6	40,9	32,6											
SX8-78/5N	18,5	25	99,6	92,9	87,1	81,4	74,3	67,9	60,7	51,1	40,7											
SX8-78/6N	22	30	120	111	105	97,7	89,1	81,4	72,9	61,3	48,9											
SX8-78/7N	26	35	140	130	122	114	104	95	85	71,5	57											
SX8-78/8N	30	40	156	146	138	128	117	107	94,5	80	63,3											
SX8-78/9N	30	40	176	164	155	144	132	120	106	90	71,2											
SX8-78/10N	37	50	195	183	173	160	147	134	118	100	79,1											
SX8-78/11N	37	50	215	201	190	176	162	147	130	110	87											
SX8-78/12N	45	60	248	232	218	203	187	171	154	130	105											
SX8-78/13N	51	70	268	251	237	220	203	185	166	141	114											
SX8-78/14N	51	70	289	271	255	237	218	200	179	152	122											
SX8-78/15N	55	75	310	290	273	254	234	214	192	163	131											
SX8-78/16N	59	80	332	312	293	274	252	232	206	176	143											
SX8-78/17N	66	90	353	332	311	292	268	247	219	187	152											
SX8-78/18N	66	90	374	351	329	309	284	261	232	198	161											
SX8-78/19N	75	100	394	371	348	326	299	276	245	209	170											
SX8-78/20N	75	100	415	390	366	343	315	290	258	220	179											
SX8-78/21N	75	100	436	409	385	361	331	304	271	231	187											
SX8-78/22N	92	125	457	428	403	378	347	318	284	242	196											
SX8-78/23N	92	125	478	448	422	395	363	333	297	253	205											
SX8-78/24N	92	125	499	467	440	412	379	347	310	264	214											

MOTORE MOTOR MOTEUR	H mm		kg
	6"	8"	
6"	644	31,5	
	770	36,5	
	896	41,5	
	1022	46,5	
	1148	51	
	1274	56	
8"	1400	61	
	1526	66	
	1652	71	
	1778	76	
	1909	82	
	2035	87	
	2161	92	
	2287	97	
	2413	101,5	
	2539	106,5	
8"	2665	111,5	
	2791	116,5	
	2917	121	
	3043	126	
	3169	131	
8"	3295	136	
	3421	141	

Le dimensioni d'ingombro e i pesi sono indicativi. - The encumbered dimensions and weight are indicative.
 Les dimensions d'encombrement et les poids sont indicatifs. - Las dimensiones y los pesos son solamente a titulo informativo.

SX8-97

POMPE SOMMERSE 8"
8" SUBMERSIBLE PUMPS
POMPES IMMERGÉES 8"
BOMBAS SUMERGIDAS 8"

50 Hz - n ≈ 2900 rpm

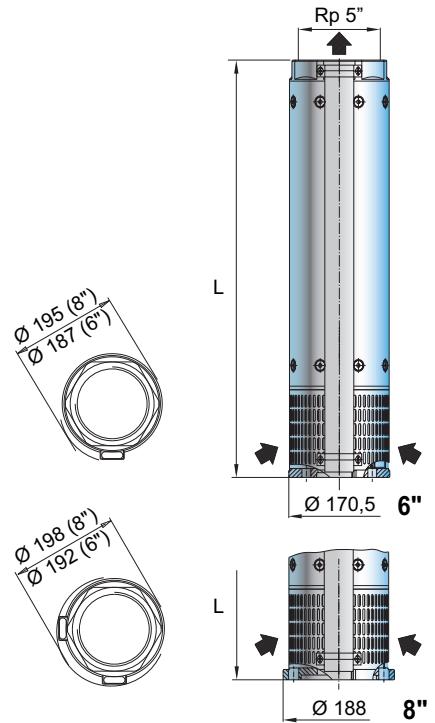
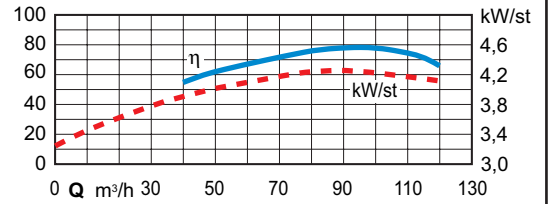
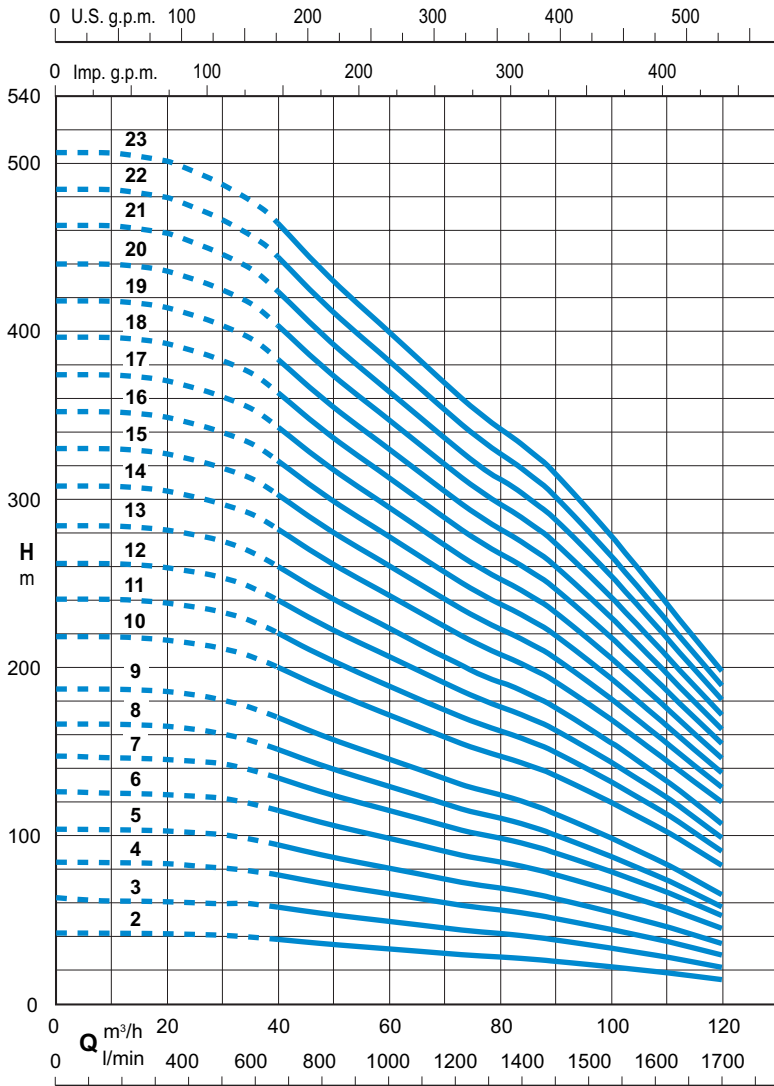

TIPO TYPE TYPE	MOTORE MOTOR MOTEUR		Q	PORTATA - DELIVERY - DEBIT - CAUDAL																				
				m³/h	0 40 50 60 70 80 90 100 110 120																			
					l/min	0	666	833	1000	1166	1333	1500	1666	1833	2000									
SX8-97/2N	9,2	12,5	H m	41,2	38,6	35,2	32,2	29,8	27,8	24,8	21,8	18,6	14,8											
SX8-97/3N	13	17,5		61,8	57,9	52,8	48,3	44,7	41,7	37,2	32,7	27,9	22,2											
SX8-97/4N	18,5	25		82,4	77,2	70,4	64,4	59,6	55,6	49,6	43,6	37,2	29,6											
SX8-97/5N	22	30		103	96,5	88	80,5	74,5	69,5	62	54,5	46,5	37											
SX8-97/6N	26	35		125	113	105	96,7	89	82,7	75	66,3	55	44											
SX8-97/7N	30	40		146	132	123	113	104	96,4	87,5	77,4	64,2	51,3											
SX8-97/8N	37	50		167	151	140	129	119	110	100	88,4	73,3	58,7											
SX8-97/9N	37	50		188	170	158	145	134	124	113	99,5	82,5	66											
SX8-97/10N	45	60		219	200	185	172	158	147	135	119	102	83,1											
SX8-97/11N	51	70		241	220	204	189	174	162	149	131	112	91,4											
SX8-97/12N	51	70		263	240	222	206	190	176	162	143	122	99,7											
SX8-97/13N	55	75		285	260	241	223	206	191	176	155	132	108											
SX8-97/14N	59	80		309	281	262	242	224	208	191	169	144	120											
SX8-97/15N	66	90		331	302	279	261	240	222	205	182	156	129											
SX8-97/16N	75	100		353	322	298	278	256	237	219	194	166	138											
SX8-97/17N	75	100		375	342	317	295	272	251	233	206	176	147											
SX8-97/18N	92	125		397	362	335	313	288	266	246	218	187	155											
SX8-97/19N	92	125		419	382	354	330	304	281	260	230	197	164											
SX8-97/20N	92	125		440	403	374	348	322	298	274	244	209	173											
SX8-97/21N	92	125		462	424	393	365	338	313	288	257	219	182											
SX8-97/22N	110	150		484	444	411	383	354	328	301	269	230	190											
SX8-97/23N	110	150		507	464	430	400	370	343	315	281	240	199											

MOTORE MOTOR MOTEUR	H	
	mm	kg
6"	644	31,5
	770	36,5
	896	41,5
	1022	46
	1148	51
	1274	56
8"	1400	61
	1526	66
	1657	72
	1783	77
	1909	82
	2035	87
	2161	92
	2287	97
10"	2413	102
	2539	106,5
	2665	111,5
	2791	116,5
	2917	121
	3043	126
	3169	131
	3295	136

Le dimensioni d'ingombro e i pesi sono indicativi. - The encumbered dimensions and weight are indicative.
 Les dimensions d'encombrement et les poids sont indicatifs. - Las dimensiones y los pesos son solamente a titulo informativo.

Radial flow pump SX6-13,18,27

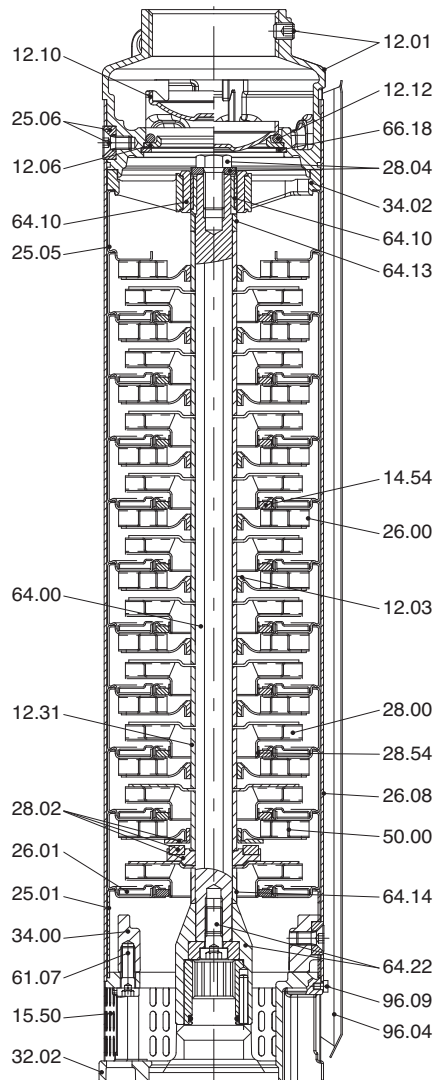

Mixed flow pump SX6-30,46,65

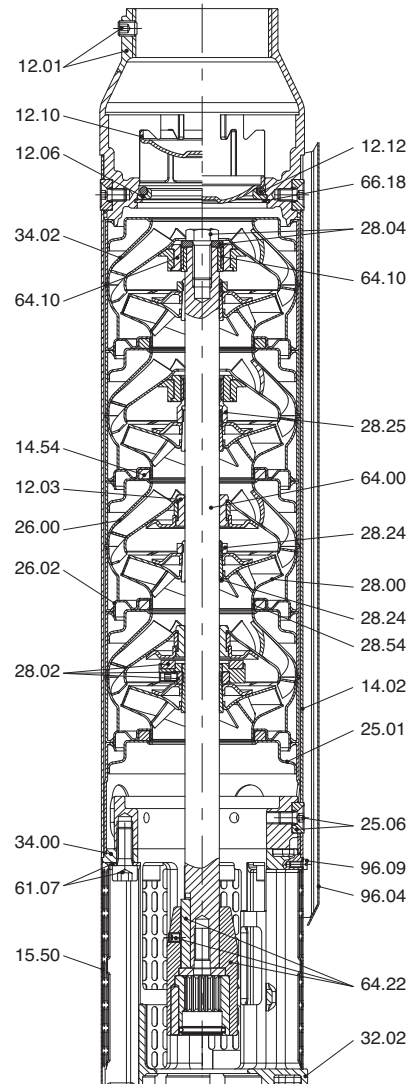

Italiano		English		Français		Español	
Nr.	Componenti	Nr.	Components	Nr.	Composants	Pos.	Componentes
12.01	Corpo di mandata	12.01	Delivery casing	12.01	Corps de refoulement	12.01	Cuerpo de impulsión
12.03	Cuscinetto di guida	12.03	Bearing bush	12.03	Coussinet	12.03	Cojinete guía
12.06	Sede valvola	12.06	Valve seat	12.06	Siège de clapet	12.06	Asiento válvula
12.10	Valvola completa	12.10	Valve set	12.10	Clapet, ensemble	12.10	Válvula completa
12.12	O-ring valvola	12.12	O-ring valve	12.12	Joint de clapet	12.12	Junta válvula
12.31	Bussola del cuscinetto	12.31	Bearing sleeve (rotating part)	12.31	Chemise d'arbre sous coussinet	12.31	Camisa del eje intermedia
14.02	Camicia esterna	14.02	External jacket	14.02	Chemise extérieure	14.02	Camisa externa
14.54	Anello di tenuta	14.54	Wear ring	14.54	Bague d'étanchéité	14.54	Anillo de cierre
15.50	Filtro	15.50	Strainer	15.50	Panier	15.50	Filtro
25.01	Corpo primo stadio	25.01	First stage casing	25.01	Corps premier étage	25.01	Cuerpo primera etapa
25.05	Corpo ultimo stadio	25.05	Last stage casing	25.05	Corps dernier étage	25.05	Cuerpo último elemento
25.06	Vite	25.06	Screw	25.06	Vis	25.06	Tornillo
26.00	Diffusore	26.00	Diffuser	26.00	Diffuseur	26.00	Difusor
26.01	Corpo stadio	26.01	Stage casing	26.01	Corps d'étage	26.01	Cuerpo elemento
26.02	Parete del diffusore	26.02	Diffuser plate	26.02	Flasque du diffuseur	26.02	Disco del diffusor
28.00	Girante	28.00	Impeller	28.00	Roue	28.00	Rodete
28.02	Anelli di contropinta	28.02	Counter thrust bearing rings	28.02	Grain de contre-boutée	28.02	Anillo contra empuje
28.04	Vite di bloccaggio	28.04	Impeller screw	28.04	Vis de blocage de roue	28.04	Tornillo fijación rodete
28.24	Bussola conica	28.24	Locking sleeve	28.24	Douille de serrage	28.24	Manguito cónico
28.25	Bussola conica	28.25	Locking sleeve	28.25	Douille de serrage	28.25	Manguito cónico
28.54	Anello di usura rotante	28.54	Rotating wear ring	28.54	Tournant la bague d'usure	28.54	Girando el anillo de desgaste
32.02	Lanterna aspirante	32.02	Suction lantern	32.02	Lanterne d'aspiration	32.02	Lanterna de aspiración
34.00	Coperchio del corpo	34.00	Casing cover	34.00	Couvercle de corps	34.00	Tapa del cuerpo
34.02	Coperchio superiore	34.02	Upper cover	34.02	Couvercle supérieur	34.02	Tapa superior
50.00	Corpo supporto inferiore	50.00	Lower bearing housing	50.00	Porte-coussinet inférieur	50.00	Cuerpo soporte inferior
61.07	Vite	61.07	Screw	61.07	Vis	61.07	Tornillo
64.00	Albero	64.00	Shaft	64.00	Arbre	64.00	Eje
64.10	Bussola cuscinetto	64.10	Bearing sleeve	64.10	Chemise (arbre) sous coussinet	64.10	Casquillo guía del cojinete
64.13	Bussola distanziatrice superiore	64.13	Upper spacer sleeve	64.13	Entretoise supérieure	64.13	Manguito distanciator superior
64.14	Bussola distanziatrice inferiore	64.14	Lower spacer sleeve	64.14	Entretoise inférieure	64.14	Manguito distanciator inferior
64.22	Giunto completo	64.22	Coupling set	64.22	Accouplement, ensemble	64.22	Manguito distanciator
66.18	Anello di sicurezza	66.18	Circlip	66.18	Circlips	64.22	Manguito acoplamiento
96.04	Copricavo	96.04	Cable guard	96.04	Profilé protégé-câble	96.04	Cubre cable
96.09	Vite	96.09	Screws	96.09	Vis	96.09	Tornillo

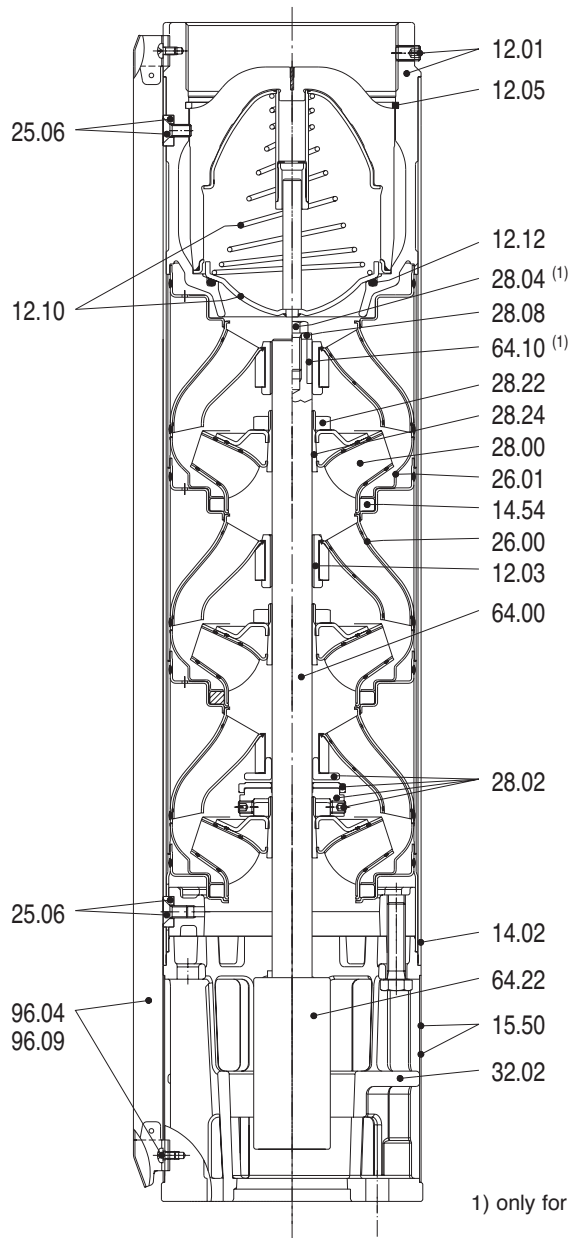

1) only for types with more than 16 stages

Italiano		Deutsch		Français		Español	
Nr.	Componenti	Nr.	Teile-Benennung	Nr.	Composants	Pos.	Componentes
12.01	Corpo di mandata	12.01	Druckgehäuse	12.01	Corps de refoulement	12.01	Cuerpo de impulsión
12.03	Cuscinetto di guida	12.03	Lagerbuchse	12.03	Coussinet	12.03	Cojinete guía
12.05	Anello di sicurezza	12.05	Sicherungsring	12.05	Circlips	12.05	Anillo de seguridad
12.10	Valvola completa	12.10	Ventil, komplett	12.10	Clapet, ensemble	12.10	Válvula completa
12.12	O-ring valvola	12.12	Ventildichtring	12.12	Joint de clapet	12.12	Junta válvula
12.31	Bussola del cuscinetto	12.31	Lagerhülse	12.31	Chemise d'arbre sous coussinet	12.31	Camisa del eje intermedia
14.02	Camicia esterna	14.02	Pumpenmantel	14.02	Chemise extérieure	14.02	Camisa esterna
14.54	Anello di tenuta	14.54	Spaltring	14.54	Bague d'étanchéité	14.54	Anillo de cierre
15.50	Filtro	15.50	Saugsieb	15.50	Panier	15.50	Filtro
25.06	Vite	25.06	Schraube	25.06	Vis	25.06	Tornillo
26.00	Diffusore	26.00	Leitrad	26.00	Diffuseur	26.00	Difusor
26.01	Corpo stadio	26.01	Staufengehäuse	26.01	Corps d'étage	26.01	Cuerpo elemento
28.00	Girante	28.00	Laufrad	28.00	Roue	28.00	Rodete
28.02	Anelli di controspinta	28.02	Gegenaxiallagering	28.02	Grain de contre-boutée	28.02	Anillo contra empuje
28.04	Vite di bloccaggio	28.04	Laufradschraube	28.04	Vis de blocage de roue	28.04	Tornillo fijación rodete
28.08	Rosetta	28.08	Scheibe	28.08	Rondelle	28.08	Arandela fijación
28.22	Dado	28.22	Mutter	28.22	Ecrou	28.22	Tuerca
28.24	Bussola conica	28.24	Spannhülse	28.24	Douille de serrage	28.24	Manguito cónico
32.02	Lanterna aspirante	32.02	Sauggehäuse	32.02	Lanterne d'aspiration	32.02	Lanterna de aspiración
34.02	Coperchio superiore	34.02	Oberer Deckel	34.02	Couvercle supérieur	34.02	Tapa superior
64.00	Albero	64.00	Welle	64.00	Arbre	64.00	Eje
64.10	Bussola cuscinetto	64.10	Lagerhülse	64.10	Chemise (arbre) sous coussinet	64.10	Casquillo guía del cojinete
64.14	Bussola distanziatrice inferiore	64.14	Abstandshülse, unten	64.14	Entretoise inférieure	64.14	Manguito distanciadore inferior
64.22	Giunto completo	64.22	Kupplung, komplett	64.22	Accouplement, ensemble	64.22	Manguito acoplamiento
96.04	Copricavo	96.04	Kabelschutzeiste	96.04	Profilé protégé-câble	96.04	Cubre cable
96.09	Vite	96.09	Schrauben	96.09	Vis	96.09	Tornillo