



Construction

Submersible motor pumps for deep wells of 6" (DN 150), 8" (DN 200) and 10" (DN 250).
 Sized for connection to the motor according to NEMA Standards.
 Delivery casing with built-in non-return valve.
 Delivery port: - threaded for 6" - flanged for 8" and 10".
Impellers - mixed flow impellers

Performance

Capacity up to 420 m³/h.
 Head up to 490 m.
 Rated motor power output up to 150 kW.
 Rotation speed 3450 r.p.m. (motor frequency 60 Hz).

Applications

For clean water, non-aggressive. For water supply. For irrigation.
 For civil and industrial applications. For fire fighting applications.

Operating conditions

Water temperature up to 25 °C.
 Max. sand quantity into the water: 150 g/m³.
 Continuous duty.
 It is suggested use electric control panels with the following starting systems: "soft starter", stator impedance, star-delta connection, for all pumps having powers higher than 11 kw.
Direction of rotation: clockwise as seen the pump from the coupling side.

Materials

Components	Materials
Suction casing	
Delivery casing	Cast iron GJL 200 EN 1561
Diffusers	(Bronze B 10 on request)
Impellers - Valve	
Shaft	Steel AISI F51 duplex
Bushing	Davlon 900 (Bronze B 14 on request)
Impeller ring	Rubber (Bronze B 14 on request)
Coupling - Cable sheat	
Filter - Bolts and screws	Stainless Steel
Shaft sleeve	Brass with chromate surface treatment (only for 10")

Coverage chart

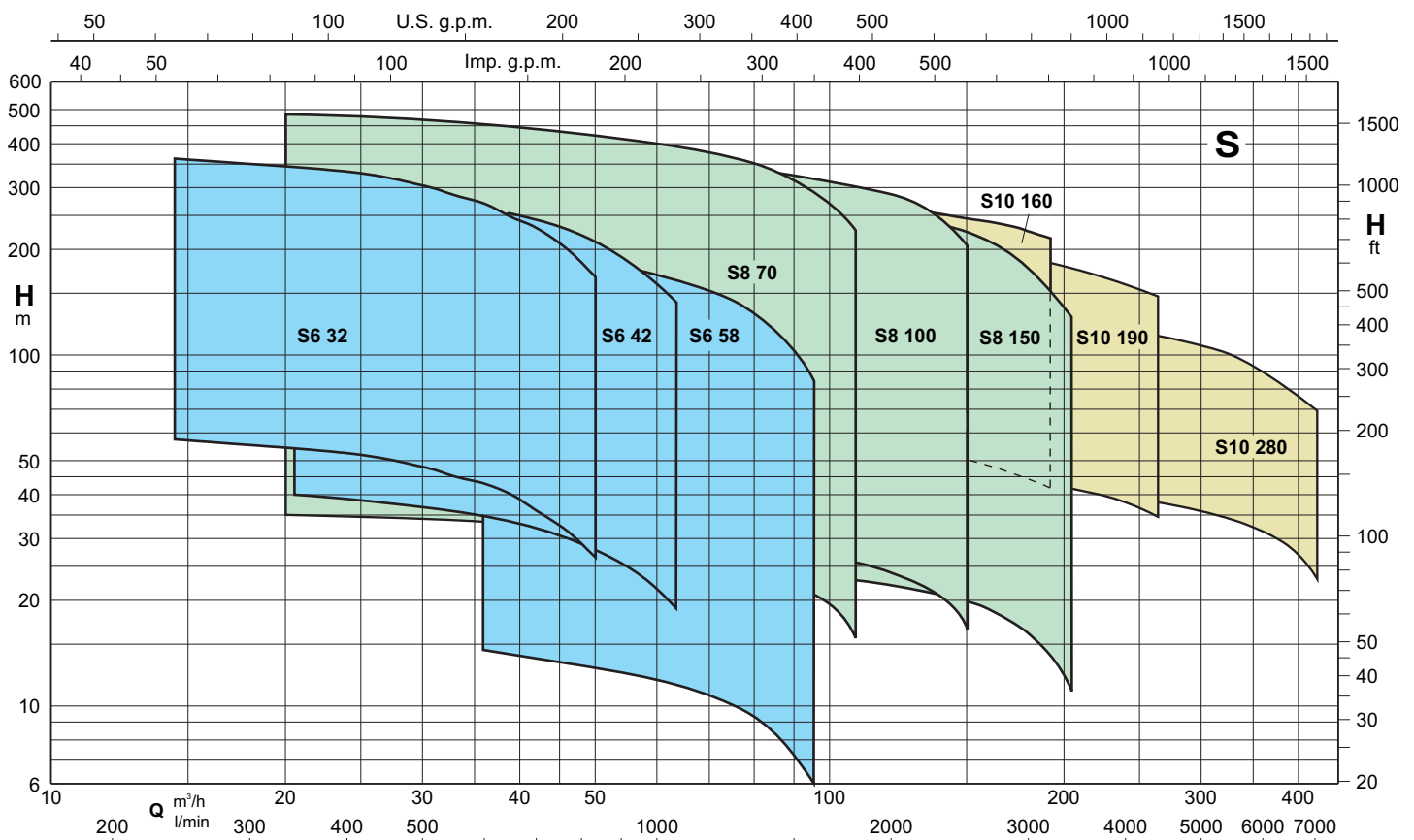

Tolerances according to ISO 9906-A

S6-32

6" MIXED-FLOW SUBMERSIBLE PUMPS

60 Hz - $n \approx 3450$ rpm

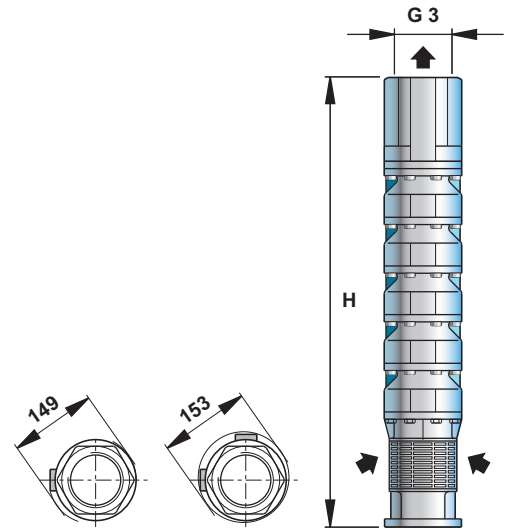
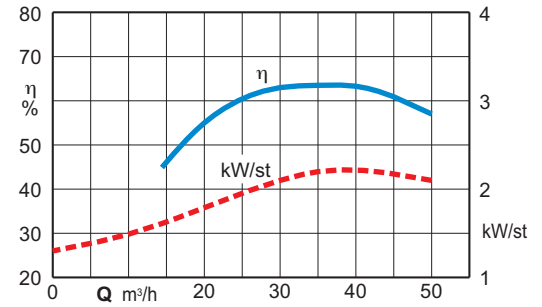
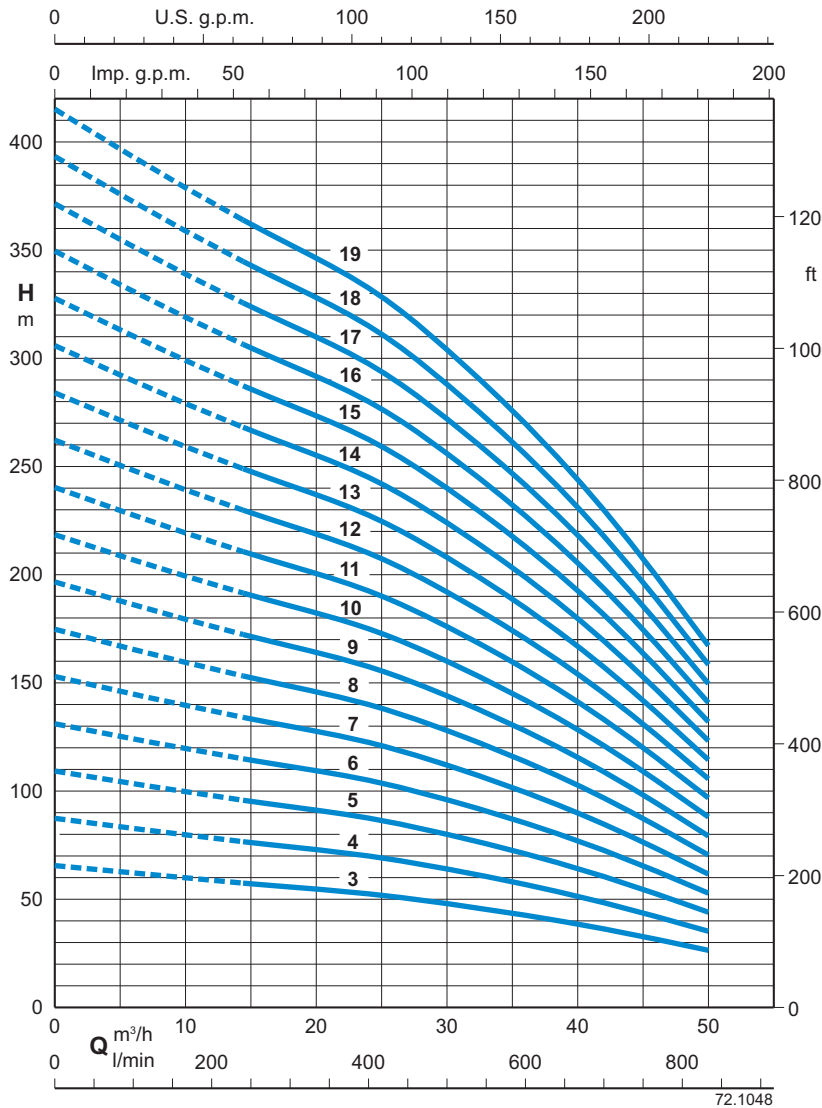

TYPE	MOTOR		Q m³/h l/min	DELIVERY											
	kW	HP		0	14,4	24	30	33	36	39	42	46	50		
S6-32/3	7,5	10	H m HEAD	66	57,5	52,5	48	45	43	40	36	31,5	26,5		
S6-32/4	9,2	12,5		88	76,5	70	64	60	57	52	48,5	42	35		
S6-32/5	11	15		110	96	87,5	80	75	71	65	60,5	52,5	44		
S6-32/6	13	17,5		132	115	105	96	90	85	78	73	63	53		
S6-32/7	15	20		154	134	123	112	105	99,5	91	85	73,5	62		
S6-32/8	18,5	25		176	153	140	128	120	114	104	97	84	70,5		
S6-32/9	18,5	25		198	172	158	144	135	128	117	109	94,5	79		
S6-32/10	22	30		220	191	175	160	150	142	130	121	105	88		
S6-32/11	22	30		242	210	193	176	165	156	143	133	115	97		
S6-32/12	26	35		264	229	210	192	180	170	156	145	126	106		
S6-32/13	26	35		286	248	228	208	195	185	169	157	136	114		
S6-32/14	30	40		308	267	245	224	210	199	182	169	147	123		
S6-32/15	30	40		330	287	263	240	225	213	195	181	157	132		
S6-32/16	37	50		352	306	280	256	240	227	208	194	168	141		
S6-32/17	37	50		374	325	298	272	255	241	221	206	178	149		
S6-32/18	45	60		396	344	315	288	270	256	234	218	189	159		
S6-32/19	45	60		418	363	333	304	285	270	247	230	200	167		

MOTOR	H	
	mm	kg
6"	681	30
	783	36
	885	41
	987	46
	1089	51
	1191	56
	1293	62
	1395	67
8"	1497	72
	1599	77
	1701	83
	1803	88
	1905	93
8"	2007	98
	2109	103
	2211	109
8"	2313	114

The encumbered dimensions and weight are indicative.

S6-42

6" MIXED-FLOW SUBMERSIBLE PUMPS

60 Hz - $n \approx 3450$ rpm

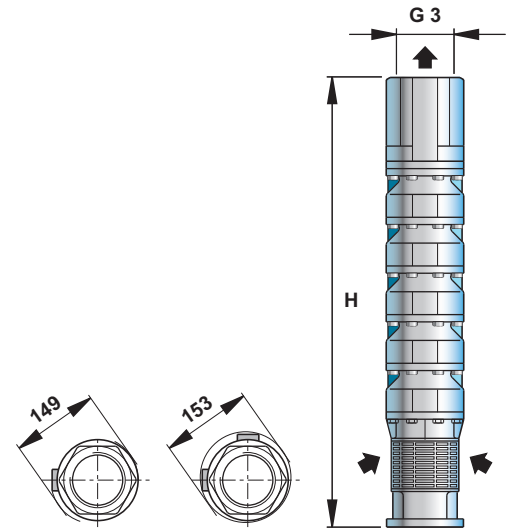
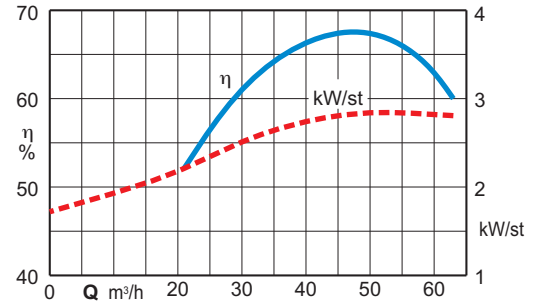
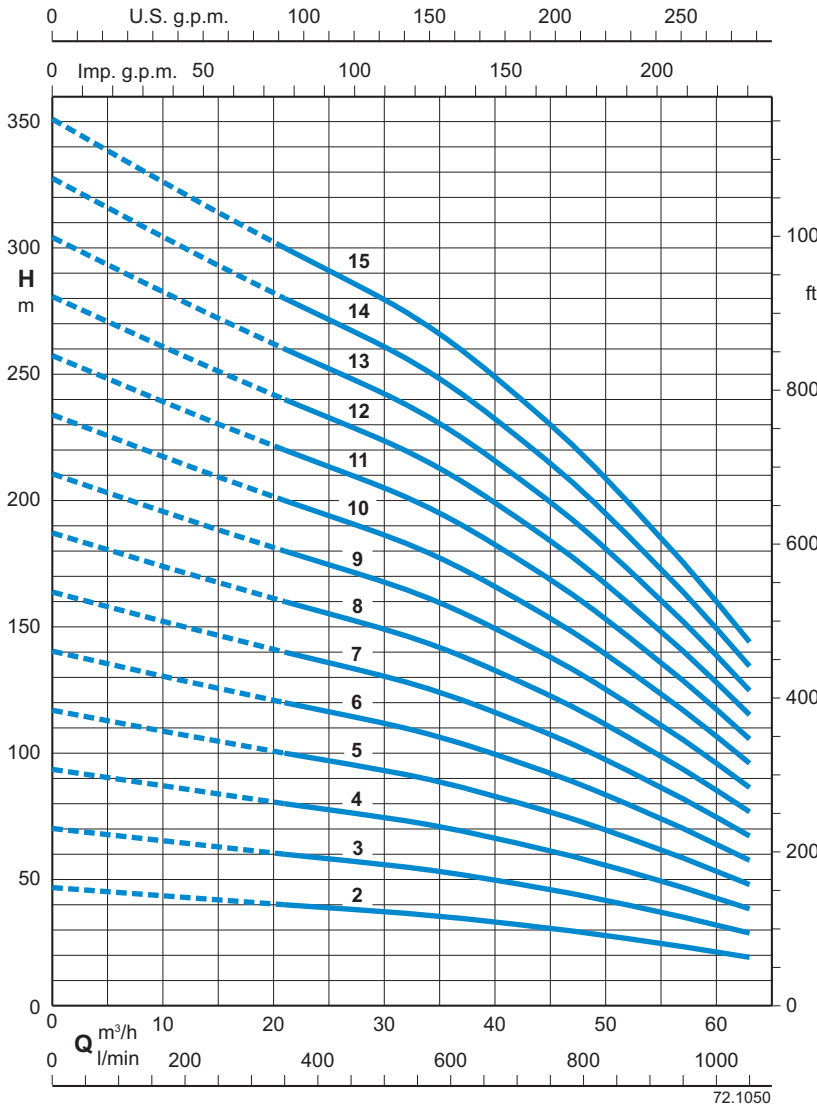

TYPE	MOTOR		Q m³/h l/min	DELIVERY									
	kW	HP		0	21	27	32	37	42	47	52	57	63
S6-42/2	5,5	7,5	H m HEAD	46	40	38	36,5	34,5	32	29,5	26,5	23,5	19
S6-42/3	9,2	12,5		70	60	57,5	55	52	48	44,5	40	35	29
S6-42/4	11	15		93	80	76,5	73	69	64,5	59	53	47	38,5
S6-42/5	15	20		116	100	95,5	91,5	86,5	80,5	74	66,5	58,5	48
S6-42/6	18,5	25		140	120	115	110	104	96,5	89	80	70	57,5
S6-42/7	18,5	25		163	140	134	128	121	113	103	93	82	67
S6-42/8	22	30		186	160	153	146	138	129	118	106	93,5	77
S6-42/9	26	35		209	180	172	165	156	145	133	120	105	86,5
S6-42/10	30	40		233	200	191	183	173	161	148	133	117	96
S6-42/11	30	40		256	220	210	201	190	177	163	146	129	105
S6-42/12	37	50		280	240	229	219	208	193	177	159	140	115
S6-42/13	37	50		302	260	248	238	225	209	192	173	152	125
S6-42/14	45	60		326	280	267	256	242	225	207	186	164	134
S6-42/15	45	60		349	300	286	274	259	241	222	199	175	144

MOTOR	H	
	mm	kg
6"	579	26
	681	31
	783	37
	885	42
	987	48
	1089	54
8"	1191	59
	1293	65
	1395	70
	1497	76
8"	1599	81
	1701	87
	1803	92
8"	1905	98

The encumbered dimensions and weight are indicative.

S6-58

6" MIXED-FLOW SUBMERSIBLE PUMPS

60 Hz - $n \approx 3450$ rpm

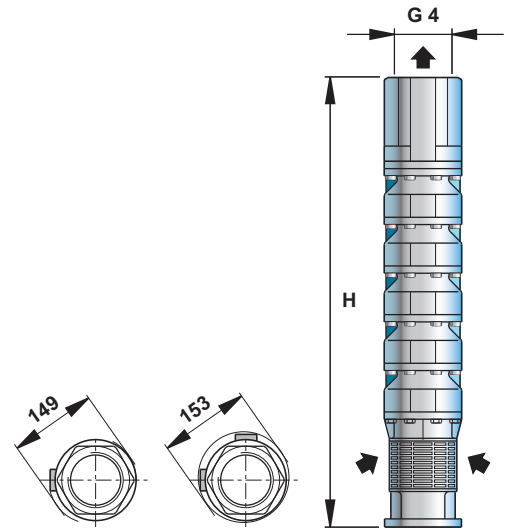
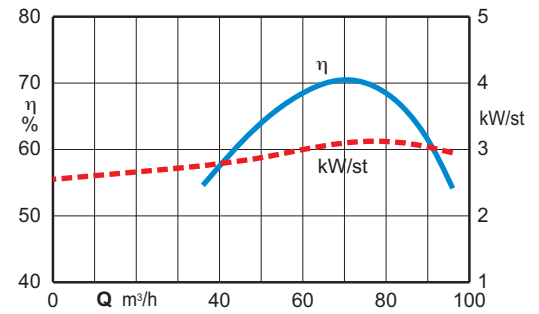
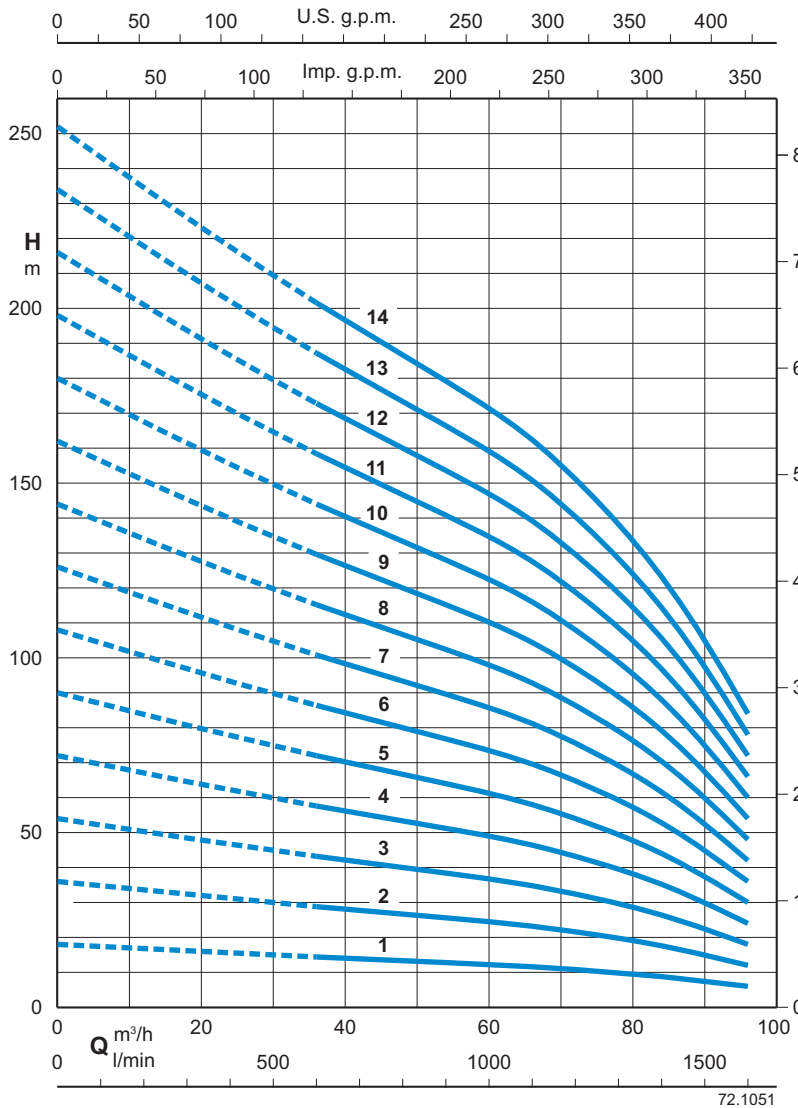

TYPE	MOTOR		Q m³/h l/min	DELIVERY											
	kW	HP		0	36	48	54	60	66	72	78	84	96		
S6-58/1	4	5,5	H m HEAD	18	14,5	13	13	12	11,5	10,5	9,5	8,5	6		
S6-58/2	5,5	7,5		36	29	26,5	26	24,5	23	21,5	19,5	17,5	12		
S6-58/3	9,2	12,5		54	43	40	38,5	36,5	35	32,5	29,5	26,5	18		
S6-58/4	11	15		72	57,5	53	51	49	46,5	43	39	35	24		
S6-58/5	15	20		90	72	66	64	61	58	54	49	44	30		
S6-58/6	18,5	25		108	86,5	79	77	73	70	65	59	53	36		
S6-58/7	22	30		126	101	92,5	90	85,5	81	75,5	68,5	61,5	42		
S6-58/8	22	30		144	115	106	102	98	93	86,5	78,5	70,5	48		
S6-58/9	26	35		162	130	119	115	110	104	97	88	79	54		
S6-58/10	30	40		180	144	132	128	122	116	108	98	88	60		
S6-58/11	37	50		198	158	145	141	134	128	119	108	97	66		
S6-58/12	37	50		216	173	158	154	146	139	130	118	106	72		
S6-58/13	45	60		234	187	172	166	159	151	140	127	114	78		
S6-58/14	45	60		252	202	185	179	171	162	151	137	123	84		

MOTOR	H	
	mm	kg
6"	477	20
	579	26
	681	31
	783	37
	885	42
	987	48
	1089	54
8"	1191	59
	1293	65
	1395	70
	1497	76
	1599	81
	1701	87
	1803	92

The encumbered dimensions and weight are indicative.

S8-70

8" MIXED-FLOW SUBMERSIBLE PUMPS

60 Hz - $n \approx 3450$ rpm

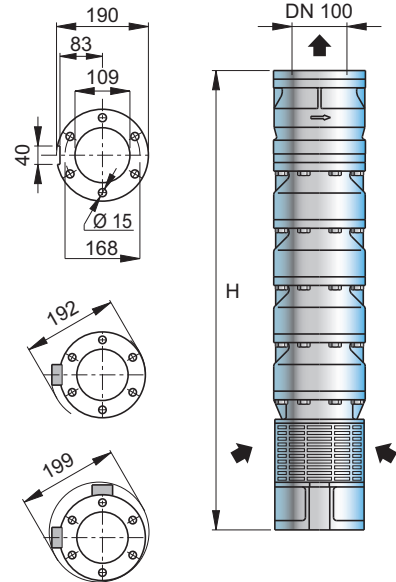
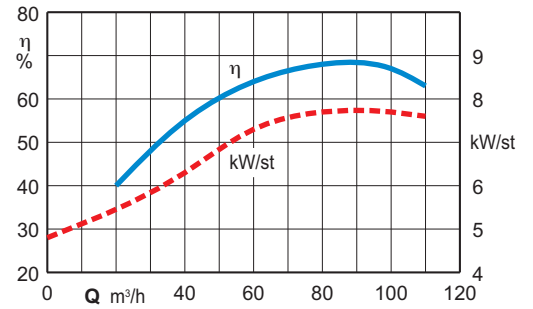
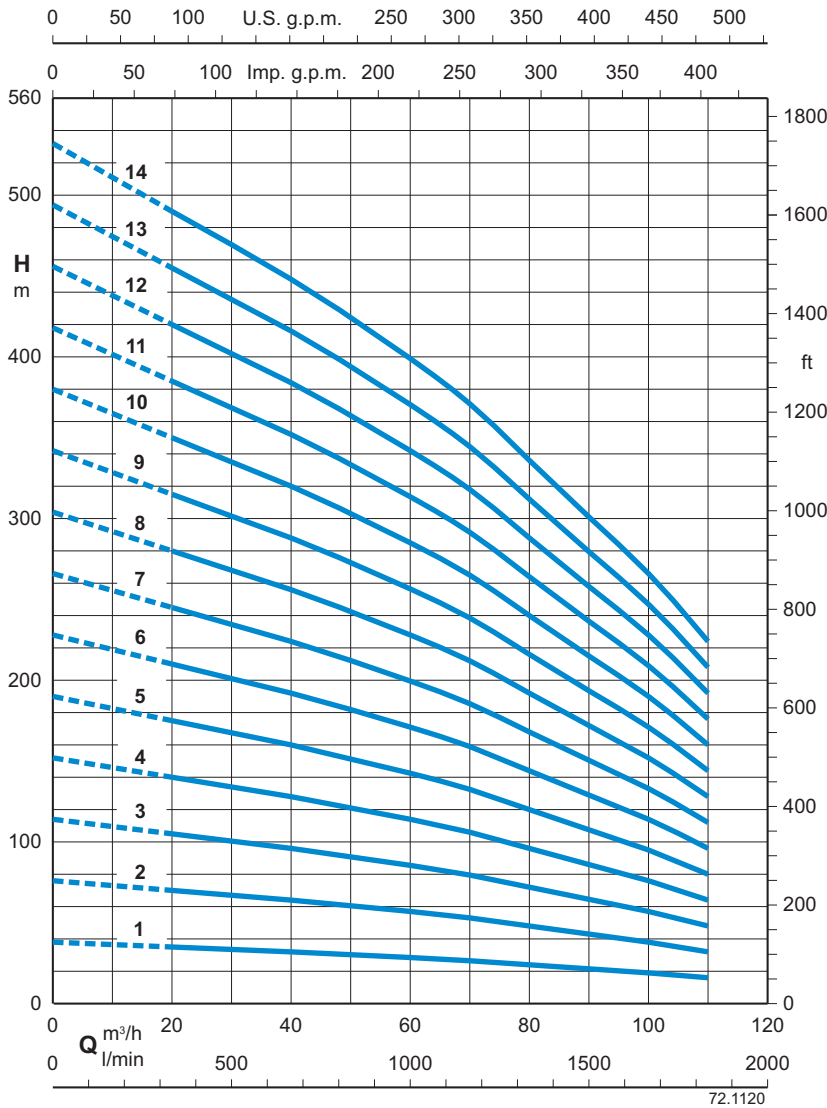

TYPE	MOTOR		Q m³/h l/min	DELIVERY												
	kW	HP		H m												
				0	20	40	50	60	70	75	80	90	100	110		
S8 70/1	7,5	10	38	35	32	30,5	28,5	26,5	25	24	21,5	19	16			
S8 70/2	15	20	76	70	64	61	57	53	50	48	43	38	32			
S8 70/3	26	35	114	105	96	91,5	85,5	79,5	75	72	64,5	57	48			
S8 70/4	30	40	152	140	128	122	114	106	100	96	86	76	64			
S8 70/5	37	50	190	175	160	153	143	133	125	120	108	95	80			
S8 70/6	45	60	228	210	192	183	171	159	150	144	129	114	96			
S8 70/7	55	75	266	245	224	214	200	186	175	168	151	133	112			
S8 70/8	59	80	304	280	256	244	228	212	200	192	172	152	128			
S8 70/9	66	90	342	315	288	275	257	239	225	216	194	171	144			
S8 70/10	75	100	380	350	320	305	285	265	250	240	215	190	160			
S8 70/11	92	125	418	385	352	336	314	292	275	264	237	209	176			
S8 70/12	92	125	456	420	384	366	342	318	300	288	258	228	192			
S8 70/13	92	125	494	455	416	397	371	345	325	312	280	247	208			
S8 70/14	110	150	532	490	448	427	399	371	350	336	301	266	224			

MOTOR	H	
	mm	kg
6"	607	40
	742	52
	877	62
	1012	73
8"	1191	88
	1326	98
	1461	109
	1596	120
10"	1731	131
	1866	143
	2001	153
	2136	165
10"	2271	175
	2406	185

The encumbered dimensions and weight are indicative.

S8-100

8" MIXED-FLOW SUBMERSIBLE PUMPS

60 Hz - $n \approx 3450$ rpm

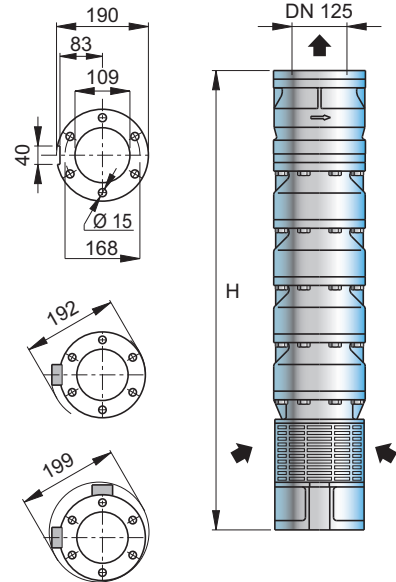
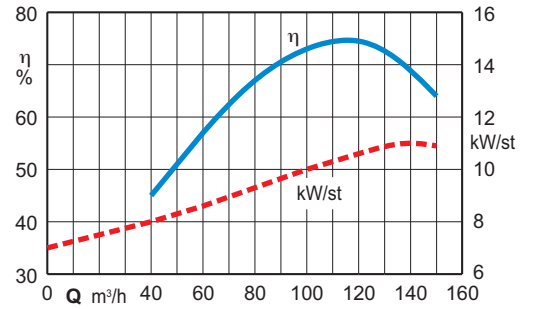
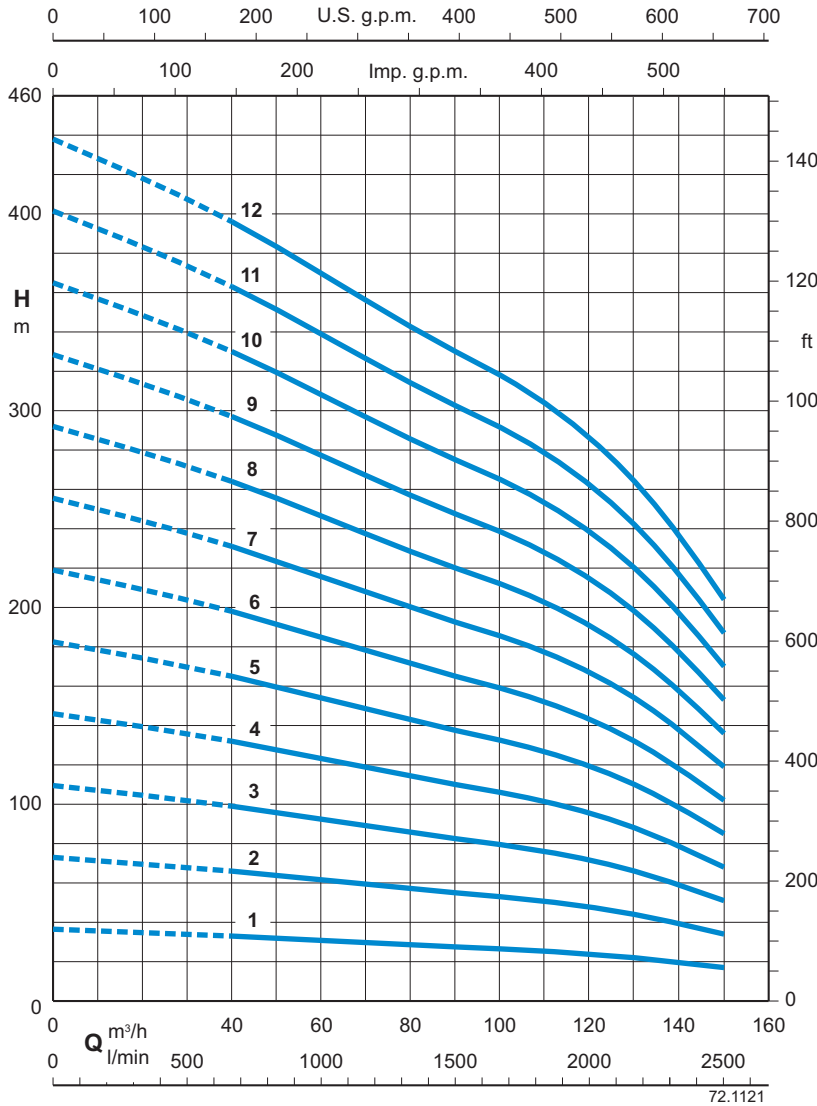

TYPE	MOTOR		Q m³/h l/min	DELIVERY										
	kW	HP		0	40	60	70	80	90	100	110	120	130	150
S8 100/1	11	15	H m HEAD	36	33	30,5	29,5	28,5	27,5	26,5	25,5	24	22	17
S8 100/2	22	30		73	66	61	59	57	55	53	51	48	44	34
S8 100/3	30	40		109	99	91,5	88,5	85,5	82,5	79,5	76,5	72	66	51
S8 100/4	45	60		146	132	122	118	114	110	106	102	96	88	68
S8 100/5	51	70		183	165	153	148	143	138	133	128	120	110	85
S8 100/6	59	80		220	198	183	177	171	165	159	153	144	132	102
S8 100/7	75	100		256	231	214	207	200	193	186	179	168	154	119
S8 100/8	92	125		293	264	244	236	228	220	212	204	192	176	136
S8 100/9	92	125		329	297	275	266	257	248	239	230	216	198	153
S8 100/10	110	150		366	330	305	295	285	275	265	255	240	220	170
S8 100/11	132	180		402	363	336	325	314	303	292	281	264	242	187
S8 100/12	132	180		440	396	366	354	342	330	318	306	288	264	204

MOTOR	H mm	kg
6"	607	40
	742	52
8"	877	62
	1012	73
	1191	88
	1326	98
10"	1461	109
	1596	120
	1731	131
	1866	143
	2001	153
	2136	165

The encumbered dimensions and weight are indicative.

S8-150

8" MIXED-FLOW SUBMERSIBLE PUMPS

60 Hz - $n \approx 3450$ rpm

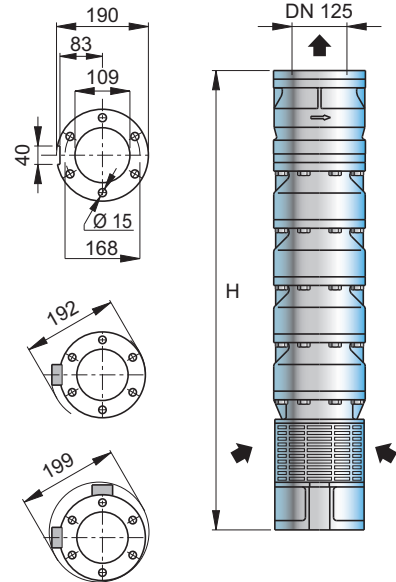
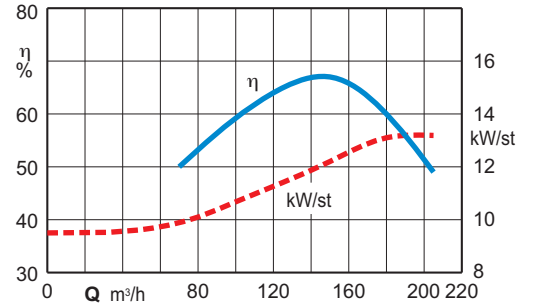
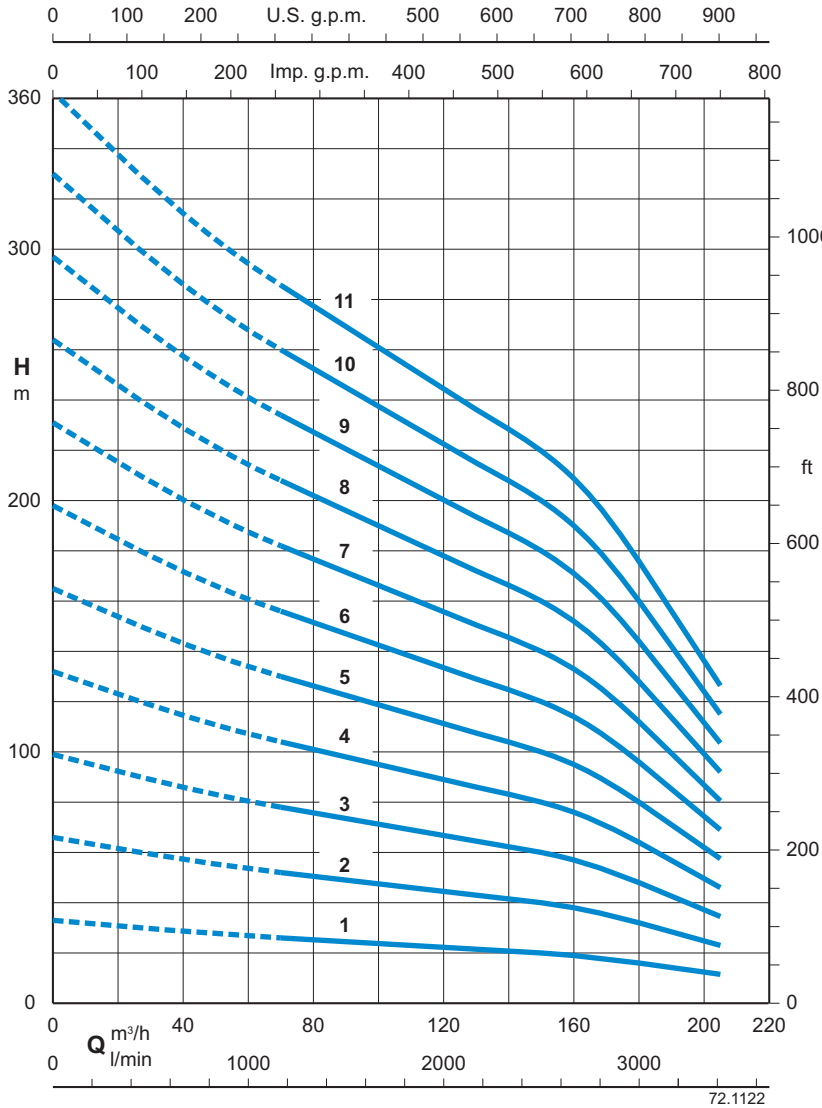

TYPE	MOTOR		Q m³/h l/min	DELIVERY										
	KW	HP		0	70	90	110	120	130	140	150	160	180	205
S8 150/1	15	20	H m HEAD	33	26	24,5	22,5	22	21,5	20,5	20	19	16	11,5
S8 150/2	30	40		66	52	49	45	44	43	41	40	38	32	23
S8 150/3	45	60		100	78	73,5	67,5	66	64,5	61,5	60	57	48	34,5
S8 150/4	51	70		133	104	98	90	88	86	82	80	76	64	46
S8 150/5	66	90		166	130	123	113	110	108	103	100	95	80	57,5
S8 150/6	75	100		199	156	147	135	132	129	123	120	114	96	69
S8 150/7	92	125		233	182	172	158	154	151	144	140	133	112	80,5
S8 150/8	92	125		266	208	196	180	176	172	164	160	152	128	92
S8 150/9	110	150		299	234	221	203	198	194	185	180	171	144	104
S8 150/10	132	180		333	260	245	225	220	215	205	200	190	160	115
S8 150/11	150	200		366	286	270	248	242	237	226	220	209	176	127

MOTOR	H mm	kg
6"	607	40
	742	52
8"	877	62
	1012	73
10"	1191	88
	1326	98
	1461	109
	1596	120
	1731	131
	1866	143
	2017	154

The encumbered dimensions and weight are indicative.

S10-160

10" MIXED-FLOW SUBMERSIBLE PUMPS

60 Hz - $n \approx 3450$ rpm

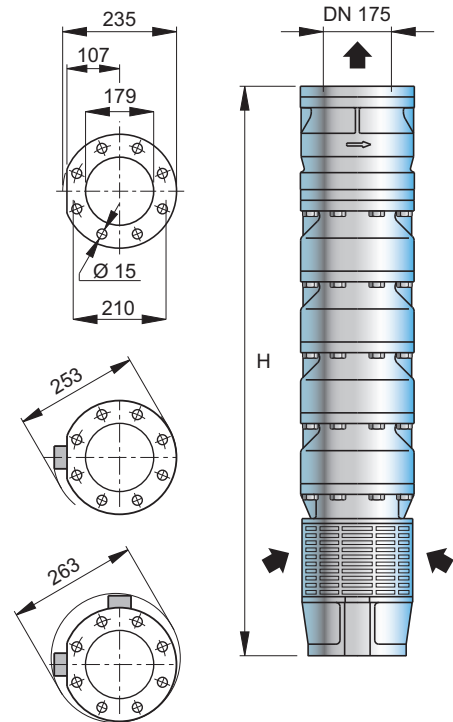
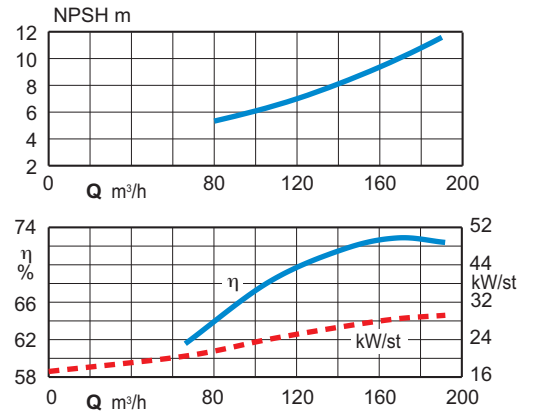
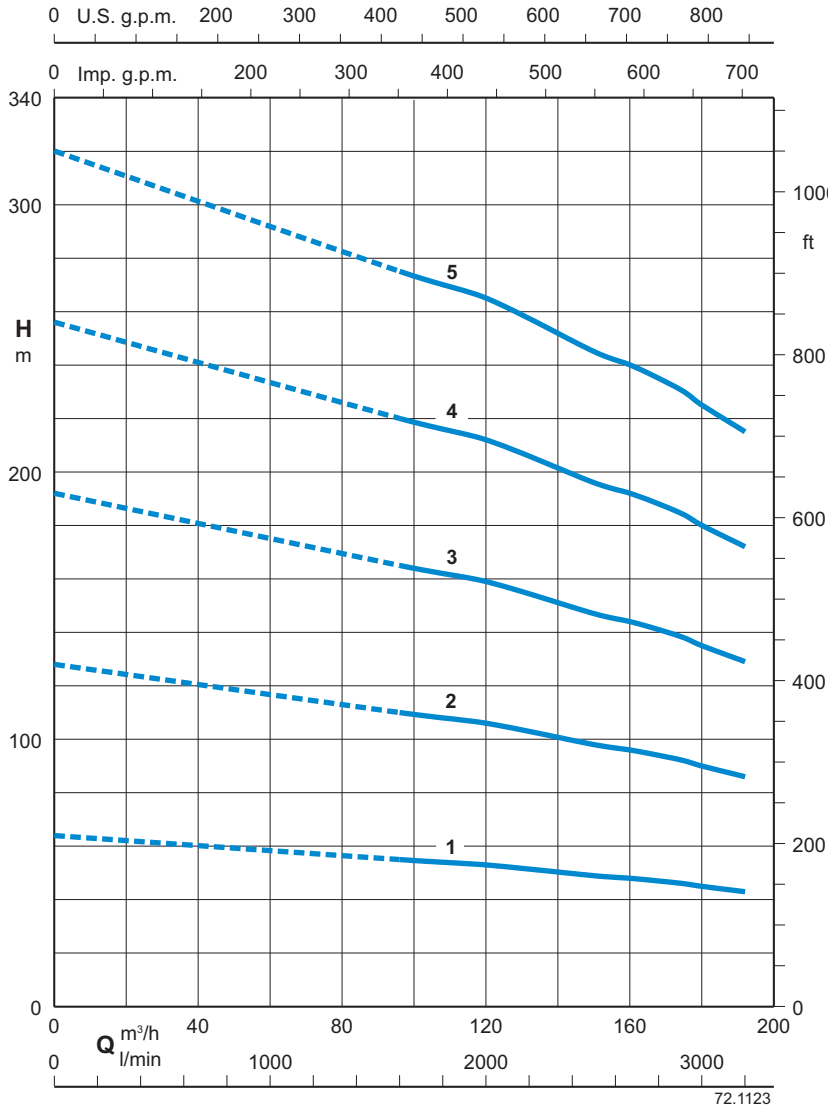

TYPE	MOTOR		Q m³/h l/min	DELIVERY														
	kW	HP		0	96	120	150	160	168	175	180	192						
S10 160/1	37	50	H m HEAD	64	55	53	49	48	47	46	45	43						
S10 160/2	75	100		128	110	106	98	96	94	92	90	86						
S10 160/3	110	150		192	165	159	147	144	141	138	135	129						
S10 160/4	132	180		256	220	212	196	192	188	184	180	172						
S10 160/5	150	200		320	275	265	245	240	235	230	225	215						

MOTOR	H mm	kg
8"	831	77
	1029	103
10"	1199	126
	1369	150
	1539	173

The encumbered dimensions and weight are indicative.

S10-190

10" MIXED-FLOW SUBMERSIBLE PUMPS

60 Hz - $n \approx 3450$ rpm

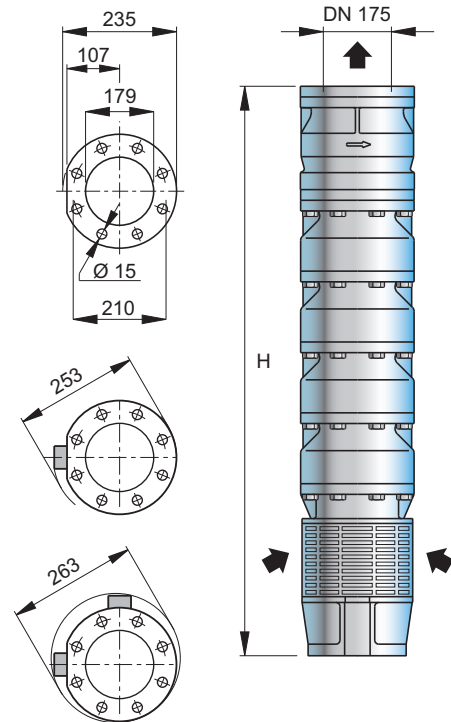
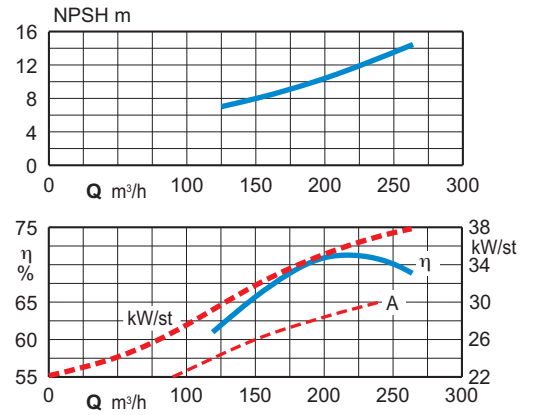
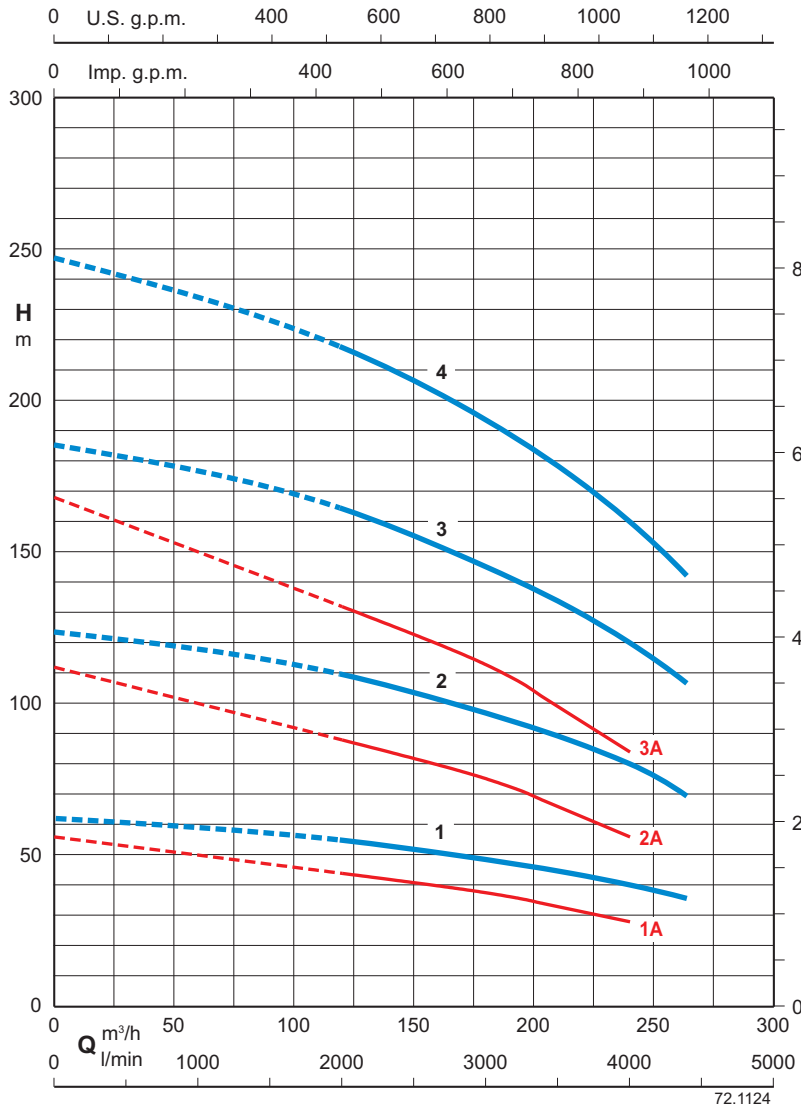

TYPE	MOTOR		Q m³/h l/min	DELIVERY									
	kW	HP		0	120	168	192	204	216	228	240	264	
S10 190/1A	30	40	H m HEAD	56	44	39	36	34	32	30	28		
S10 190/1	37	50		62	55	49	46	44	41	40	39	35	
S10 190/2A	59	80		112	88	78	72	68	64	60	56		
S10 190/2	75	100		124	110	99	92	88	83	80	78	69	
S10 190/3A	92	125		168	132	117	108	102	96	90	84		
S10 190/3	110	150		186	164	150	138	132	125	120	116	104	
S10 190/4	150	200		248	219	199	184	176	166	160	155	149	

MOTOR	H	
	mm	kg
8"	831	78
	831	78
	1029	103
	1029	103
10"	1199	127
	1199	127
	1369	151

The encumbered dimensions and weight are indicative.

S10-280

10" MIXED-FLOW SUBMERSIBLE PUMPS

60 Hz - n ≈ 3450 rpm

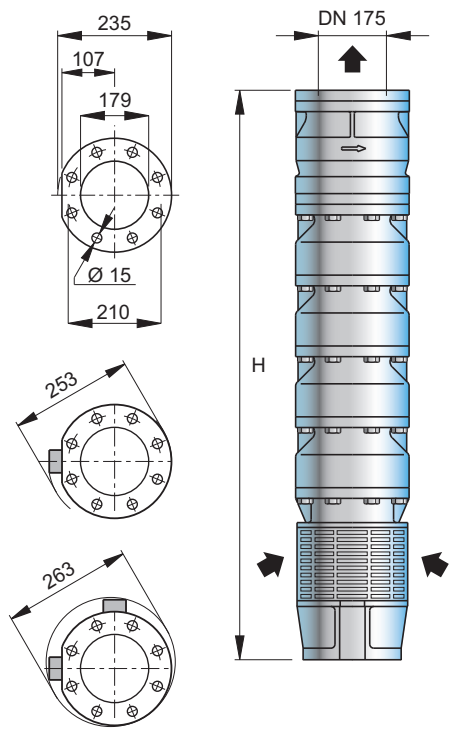
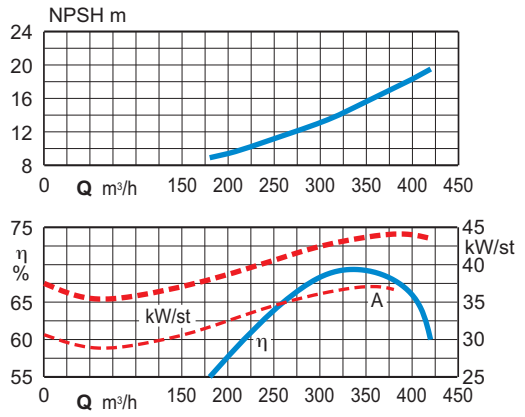
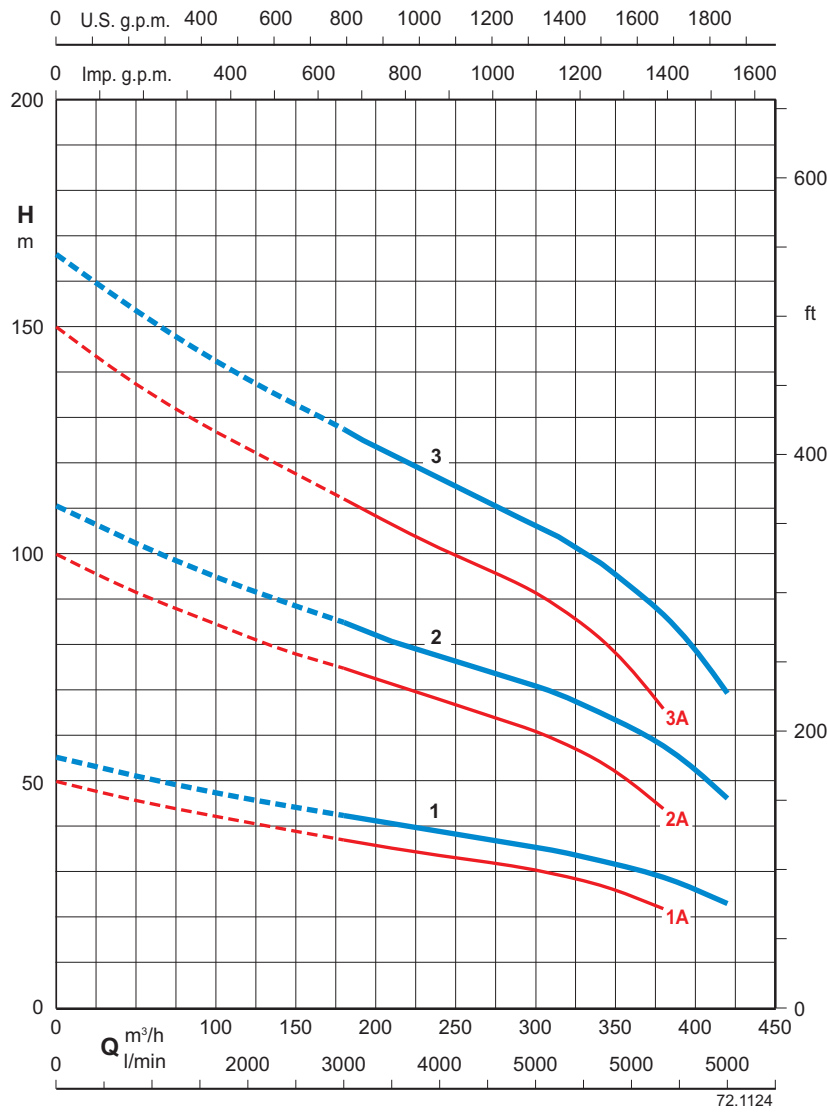

TYPE	MOTOR		Q	DELIVERY									
	kW	HP		m³/h	0	180	240	280	300	320	340	380	420
			l/min	0	3000	4000	4667	5000	5333	5667	6333	7000	
S10 280/1A	37	50	HEAD	50	38	34	32	31	29	27	22		
S10 280/1	45	60		55	43	38	37	36	34	33	29	23	
S10 280/2A	75	100		100	75	67	64	61	58	54	44		
S10 280/2	92	125		110	85	77	73	71	68	65	58	46	
S10 280/3A	110	150		150	113	101	96	92	87	82	66		
S10 280/3	132	180		165	128	115	109	107	103	98	87	69	

MOTOR	H	
	mm	kg
8"	831	78
	831	78
	1029	103
10"	1029	103
	1199	127
	1199	127

The encumbered dimensions and weight are indicative.

S6

Drawing for dismantling and assembly

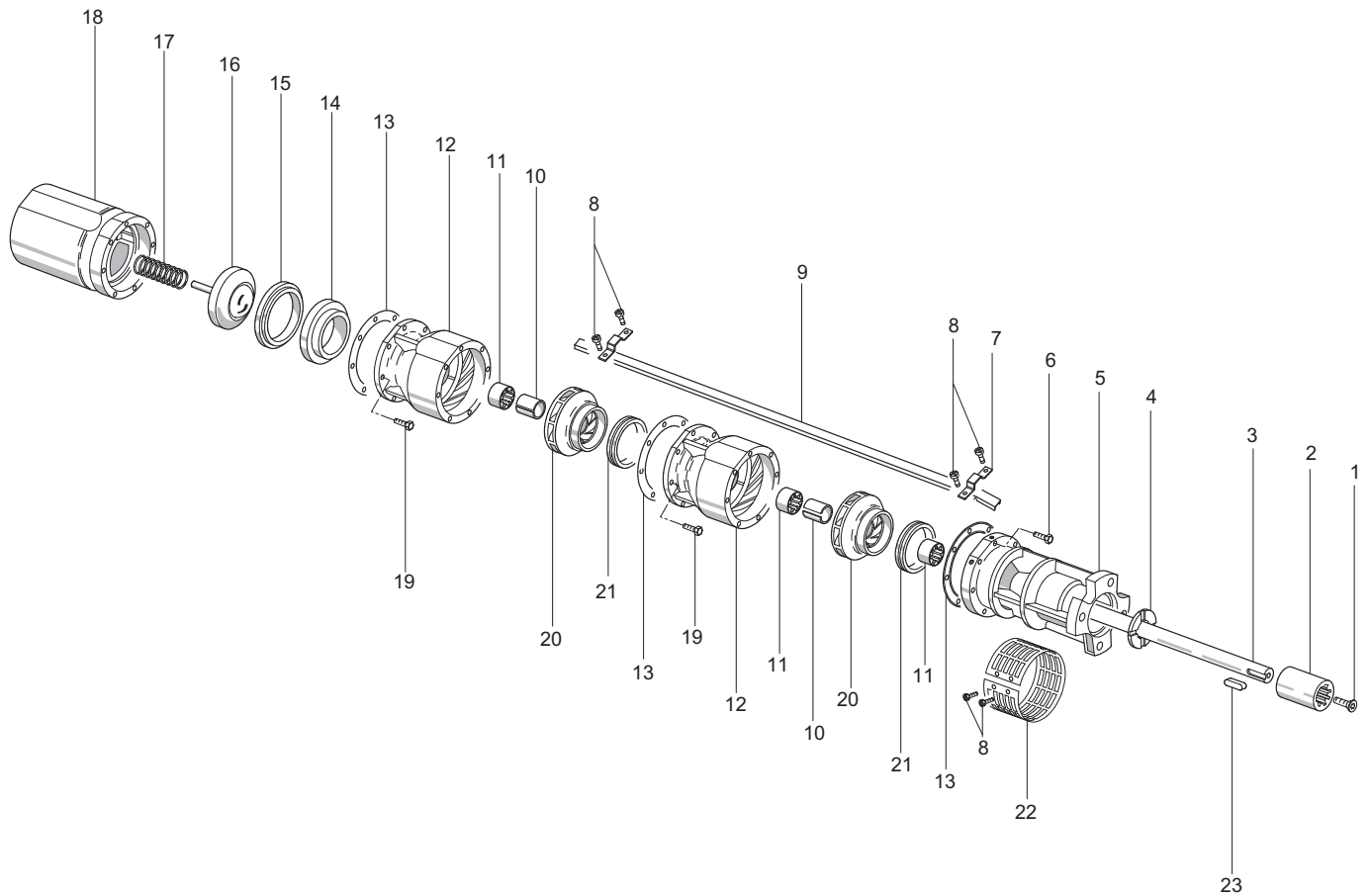

Pos. N°	DENOMINATION	Q.ty.
1	Joint screw M10x16	1
2	Joint	1
3	Shaft	1
4	Pump thrust bearing	1
5	In-let support	1
6	Screw M8x25	8
7	Cable cover clips	2
8	Screw M5x10	6
9	Cable cover	1
10	Conic bushing	1 x st
11	Bushing	1 x st
12	Diffuser	1 x st
13	Gasket	1 x st
14	Valve seat	1
15	Valve gasket	1
16	Retaining valve	1
17	Spring	1
18	Delivery support	1
19	Screw M8x20	8 x st
20	Impeller	1 x st
21	Impeller ring	1 x st
22	Suction screen	1
23	Joint key	1

To order spare parts, please specify :
 - description,
 - reference number,
 - pump type

S8

Drawing for dismantling and assembly

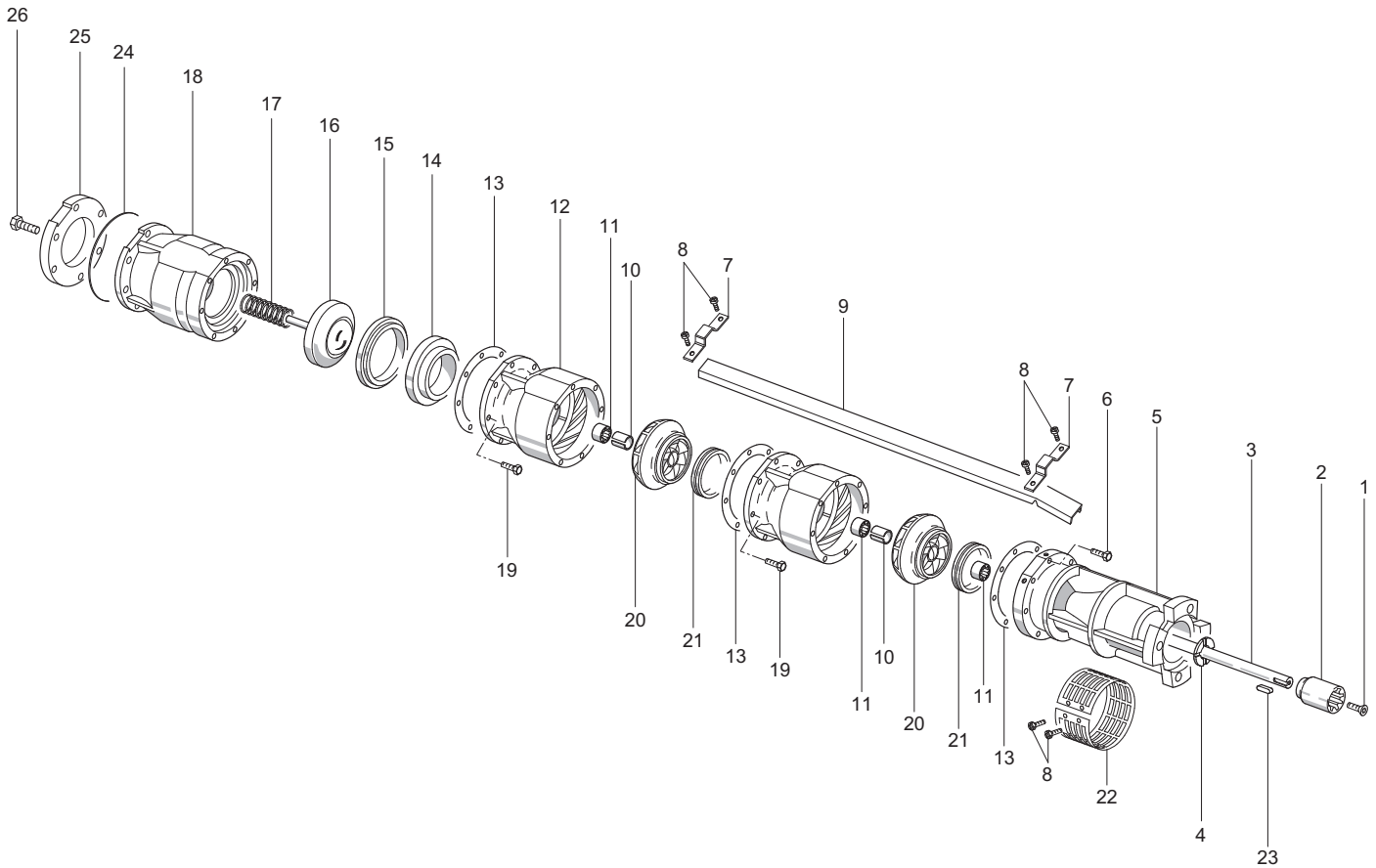

Pos. N°	DENOMINATION	Q.ty.
1	Joint screw M10x16	1
2	Joint	1
3	Shaft	1
4	Pump thrust bearing	1
5	In-let support	1
6	Screw M10x30	8
7	Clamp	2
8	Screw M5x10	6
9	Cable cover	1
10	Conic bushing	1 x st
11	Bushing	1 x st
12	Diffuser	1 x st
13	Gasket	1 x st
14	Valve seat	1
15	Valve gasket	1
16	Retaining valve	1
17	Spring	1
18	Delivery support	1
19	Screw M10x25	8 x st
20	Impeller	1 x st
21	Impeller ring	1 x st
22	Suction screen	1
23	Joint key	1
24	Flange OR	1
25	Flange	1
26	Screw M14x35	6

To order spare parts, please specify :
 - description,
 - reference number,
 - pump type

S10

Drawing for dismantling and assembly

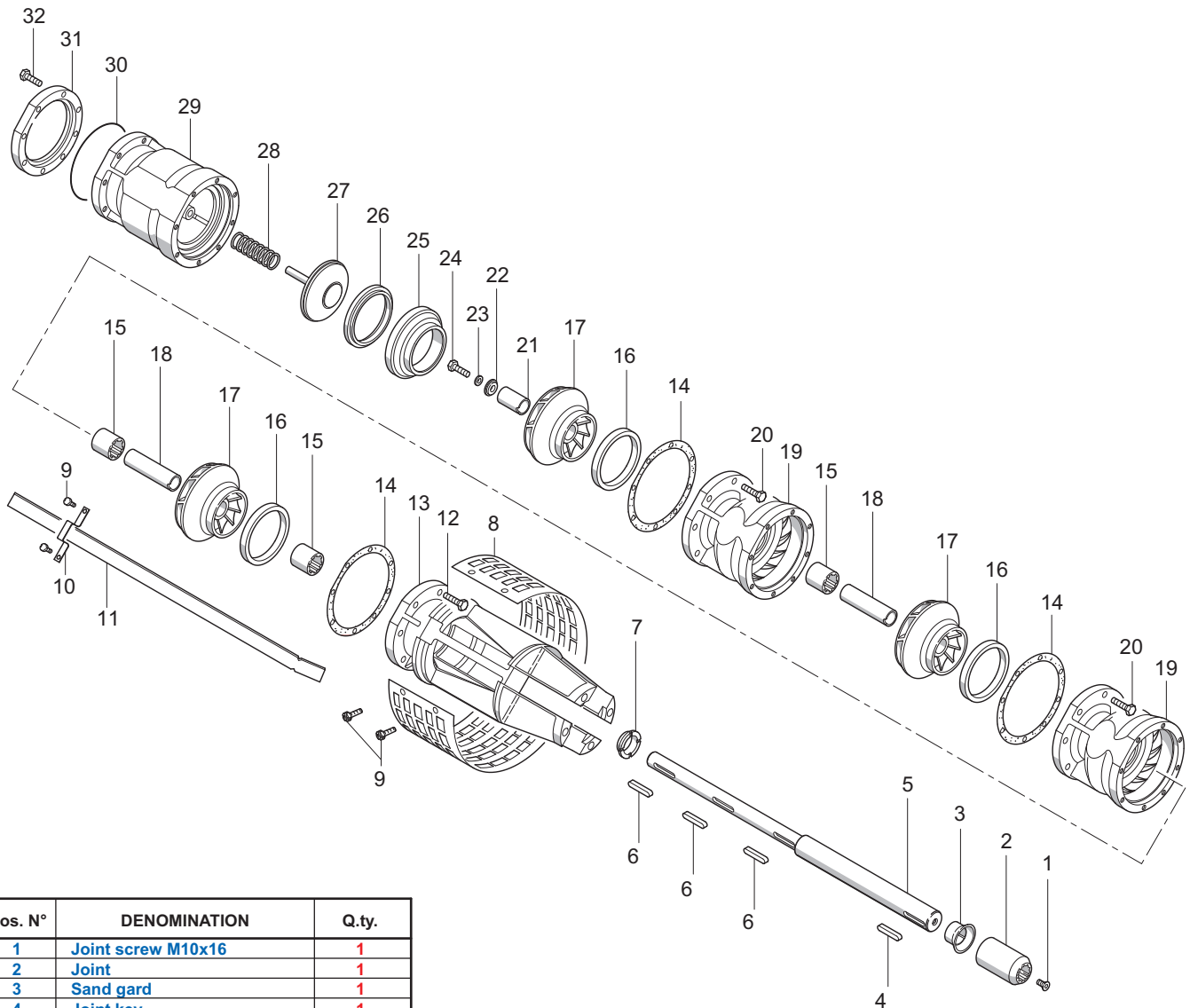

Pos. N°	DENOMINATION	Q.ty.
1	Joint screw M10x16	1
2	Joint	1
3	Sand gard	1
4	Joint key	1
5	Shaft	1
6	Impeller key	1 x st
7	Pump thrust bearing	1
8	Suction screen	1
9	Screw M5x10	4
10	Clamp	1
11	Cable cover	1
12	Screw M12x40	8
13	In-let support	1
14	Gasket	1 x st
15	Bushing	1 x st
16	Impeller ring	1 x st
17	Impeller	1 x st
18	Chromate bushing	1 x st
19	Diffuser	1 x st
20	Screw M12x35	8 x st
21	Head bushing	1
22	Washer	1
23	Grover M12	1
24	Screw M12x30	1
25	Valve seat	1
26	Valve gasket	1
27	Retaining valve	1
28	Spring	1
29	Delivery support	1
30	OR	1
31	Flange	1
32	Screw M14x35	8

To order spare parts, please specify :
 - description,
 - reference number,
 - pump type